



## KSFS · KSFS-...-Ex

### Ducted particulate filters

**TROX GmbH**  
Heinrich-Trox-Platz  
47504 Neukirchen-Vluyn  
Germany  
Phone: +49 (0) 2845 2020  
Fax: +49 (0) 2845 202265  
E-mail: trox@trox.de  
Internet: <http://www.trox-technik.com>

#### Product overview

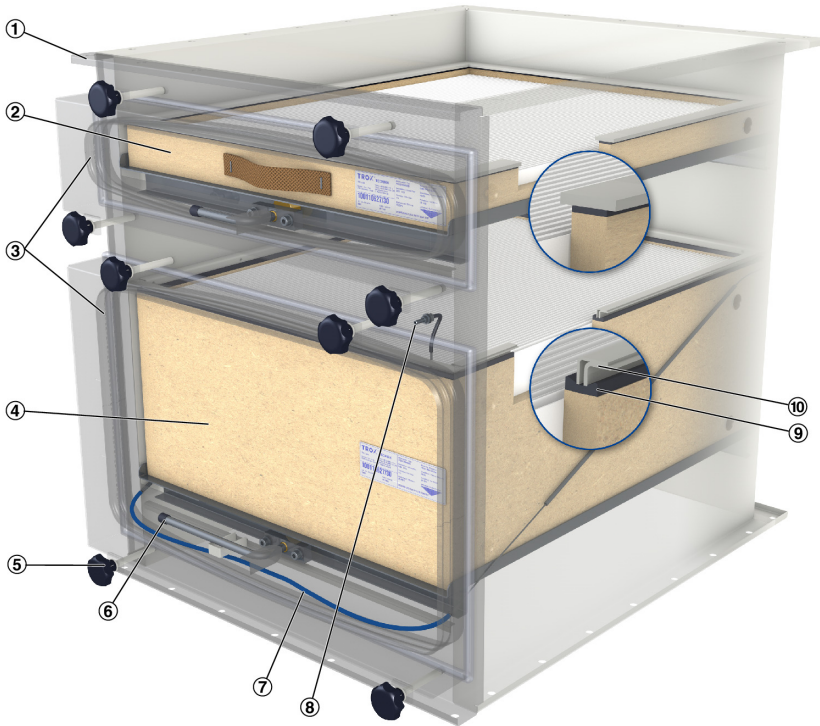

Fig. 1: Schematic illustration, e.g. KSFS-...-Ex

- |   |  |   |  |
|---|--|---|--|
| ① | Flange                                 | ⑥ | Clamping frame for the filter element    |
| ② | Prefilter                              | ⑦ | Ejection mechanism for filter change     |
| ③ | Double-groove service board (optional) | ⑧ | Spigot for sealing integrity test groove |
| ④ | Main filter                            | ⑨ | Filter seal                              |
| ⑤ | Star knob screw of cover               | ⑩ | Integral sealing integrity test groove   |

## Important notes

### Information on the installation manual

This manual enables operating or service personnel to correctly install the product described below and to use it safely and efficiently.

It is essential that these individuals read and fully understand this manual before starting any work. The basic prerequisite for safe working is to comply with the safety notes and all instructions in this manual.

The local regulations for health and safety at work and general safety regulations also apply.

### Correct use

The ducted particulate filter of Type KSFS and KSFS-...-Ex (explosion-proof construction) is designed as a filter casing for duct installation. The filter casing is used to separate suspended particles from the supply or extract air in ventilation and air conditioning systems.

Usable filter elements:

- For the separation of suspended particles such as aerosols, toxic dusts, viruses and bacteria from the supply or extract air.
  - GAL/STA Mini Pleat filter panels
  - MFP-MDF Mini Pleat filter panels (not for explosion-proof construction KSFS-...-Ex)
  - Mini Pleat filter cells MFC-GAL/STA
- For the separation of gaseous odorous substances and contaminants from the supply and extract air.
  - Activated carbon filter cells AFC (not for explosion-proof construction KSFS-...-Ex)

### Information on explosion protection



**EXPLOSION HAZARD!**  
Unit components that comply with Directive 2014/34/EU include additional information on the rating plate.

The filter may be used in an area with the potentially explosive atmosphere of zones 1, 2 and 21, 22.

### Explosion protection labelling:

	II 2G Ex IIC T6 Gb
	II 2D Ex IIIB T80 °C Db

Conformity in accordance with guide-lines	2014/34/EU
Equipment group (2014/34/EU)	II and III
Equipment category (2014/34/EU)	2G and 2D
Ex-areas (1999/92/EC)	Zones: 1, 2, 21, 22

The filter casing, filter chamber cover and the filter frame must be connected to the earth potential. All conductive and dissipative parts must be connected together and grounded.

Conductive dusts are excluded from the application. Under no circumstances should metallic foreign materials enter the filter.

Further operating instructions and explosion protection documents in the sense of the guideline 1999/92/EC, as well as the industry-usual guidelines for use, handling, maintenance and disposal of air filters for ventilation and air conditioning systems SWKI 2003 and VDI 6022, must be followed.

### Airflow velocity and nominal volume flow rate

During proper use and compliance with the nominal volume flow rate, an airflow velocity of 3.36 m/s is usually not exceeded on the filter medium, even if the filter has reached the maximum final differential pressure. As a guideline for the dimensioning, the specific maximum air flow rate of 0.2m³/s per m² of filter area is used.

Compliance with the nominal flow rate must be ensured by test and monitoring devices within the system (e.g. pressure differential monitors or flowmeters).

It is important that you comply with any national hygiene regulations during installation, commissioning or use.

## Incorrect use



### WARNING!

#### Danger due to incorrect use!

Misuse of the filter can lead to dangerous situations.

- Use filters only in explosion-proof areas that correspond to the above zones;
- Use filter only with mounted grounding set;

## Limitation of liability

The information in this manual has been compiled with reference to the applicable standards and guidelines, the state of the art, and our expertise and experience of many years.

The manufacturer does not accept any liability for damages resulting from:

- Non-compliance with this manual
- Incorrect use
- Operation or handling by untrained individuals
- Unauthorised modifications
- Technical changes
- Use of non-approved replacement parts

The actual scope of delivery may differ from the information in this manual for bespoke constructions, additional order options or as a result of recent technical changes.

The obligations agreed in the order, the general terms and conditions, the manufacturer's terms of delivery, and the legal regulations in effect at the time the contract is signed shall apply.

We reserve the right to make technical changes.

## Defects liability

For details regarding defects liability please refer to Section VI, Warranty Claims, of the Delivery and Payment Terms of TROX GmbH.

The Delivery and Payment Terms of TROX GmbH are available at [www.troxtechnik.com](http://www.troxtechnik.com).

## Qualified staff

### Properly trained person

Properly trained persons are trained individuals who understand any potential hazards related to the work under consideration, and who recognise and avoid any risks involved. Training is provided by the HVAC contractor when the system is handed over.

Properly trained persons are responsible for cleaning the unit, and for carrying out functional tests, regular checks and smaller adjustments.

## Personal protective equipment

Personal protective equipment must be worn for any work in order to reduce health or safety hazards to the minimum.

The appropriate protective equipment for a job must be worn for as long as the job takes.

## Industrial safety helmet



Industrial safety helmets protect the head from falling objects, suspended loads, and the effects of striking the head against stationary objects.

## Light respiratory protection



Light respiratory protection is used to provide protection from harmful dusts.

## Protective gloves



Protective gloves protect hands from friction, abrasions, punctures, deep cuts, and direct contact with hot surfaces.

## Supply package, transport and storage

### Supply package

- Casing
- Filter element (optional)

### Transport



#### **CAUTION!**

#### **Danger of injury from sharp edges, sharp corners and thin sheet metal parts!**

Sharp edges, sharp corners and thin sheet metal parts may cause cuts or grazes.

- Be careful when carrying out any work.
- Wear protective gloves, safety shoes and a hard hat.

Use only lifting and transport gear designed for the required load. Always secure the load against tipping and falling.

Upon delivery, carefully remove the packaging and check the unit for transport damage and completeness.

### Storage

Please note:

- Store the unit only in its original packaging
- Protect the unit from the effects of weather
- Protect the unit from humidity, dust and contamination
- Storage temperature: -10 °C to 50 °C.
- Relative humidity: 95 % max., no condensation

## Assembly

### General information

Ducted particulate filters of Type KSFS are connected directly to the duct via flanges using optional spigots. The unit weight must be compensated by on-site measures (suspensions or similar).

- Fix the unit only to load-bearing structures.
- Load suspension systems only with the weight of the unit. Adjacent components and connecting ducts must be supported separately.
- Do not unpack and insert/install the filter until directly before commissioning.

### ! NOTICE!

#### Possible malfunction due to a damaged casing

If the casing has been damaged, unfiltered (contaminated) air may leak.

Do not drill any holes into the casing.



*If there is a lengthy break between installation and commissioning, cover all openings of the casing (e.g. with plastic) to protect the interior and avoid cumbersome cleaning procedures at the time of commissioning.*

### Earthing connections KSFS-...-Ex

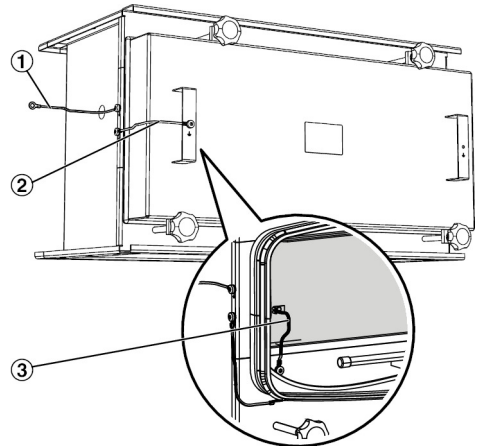

Fig. 2: Earthing connection

- 1 Earthing connection of filter casing
- 2 Earthing connection of filter chamber cover
- 3 Earthing connection of filter element (filter chamber cover removed)

### ⊕ EXPLOSION HAZARD!

*Connect the filter casing to the equipotential bonding of the building via the earthing cable (Fig. 2/1). When operating the explosion-proof filter, all earthing cables must be installed, as shown in Fig. 2.*

## Connecting the ductwork

Type KSFS ducted particulate air filters are supplied as follows:

- with flanges
- with spigots

Connect the duct in such a way that the connection is tight.

To protect the filter elements once installed as much as possible from excessive contamination, proceed as follows when you install the ventilation system:

- Keep the ducts clean when you install them.
- If you have to interrupt the installation procedure, protect all openings from the ingress of dust.
- If necessary, clean the ducts before you commission the ventilation system.

## Commissioning

### General information

Before you start commissioning:

- Check that the filter casings are correctly seated.
- Remove protective film, if any.
- Ensure that all filter casings are clean and free from residues and foreign matter.
- Prime the ventilation and air conditioning system for 24 hours before you insert the filter element.

## Filters, inserting

**Note:** The insertion of the filter is described using the main filter as an example; the insertion of the prefilter is identical.

- Do not unpack filter elements until you are ready to install them.
- Do not touch the filter; hold it by the edge only.
- Check filter elements for any damage; replace damaged filter elements.
- Insert only suitable Mini Pleat filter elements with a flat seal or fluid seal.

1. ▶



**EXPLOSION HAZARD!**

*KSFS-...-Ex: Remove the earthing cable from the filter chamber cover (Fig. 2/2).*

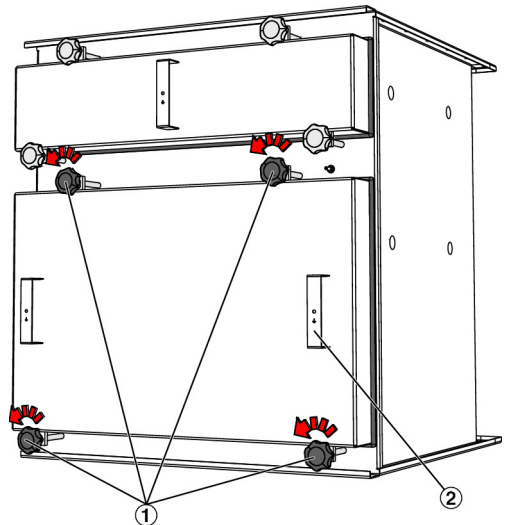

*Fig. 3: Opening the filter chamber cover*

2. ▶ Unscrew the clamping screws (Fig. 3/1) on the filter chamber cover using the star grip. Remove the filter chamber cover from the filter casing by both handles (Fig. 3/2) and store it.

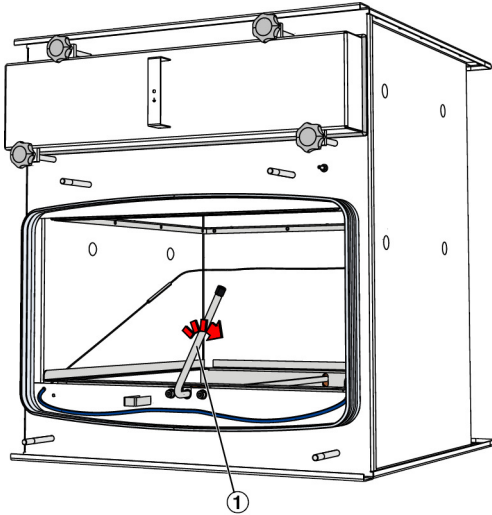

Fig. 4: Releasing the clamping frame

3. ▶ Release the clamping frame by turning the operating lever (Fig. 4/1) clockwise.

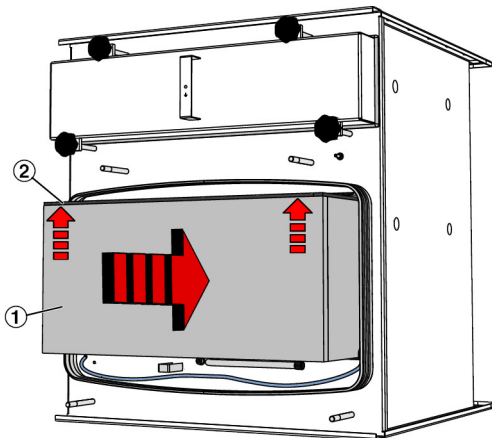

Fig. 5: Filters, inserting

4. ▶ **! NOTICE!**  
Do not damage the filter.  
Handle filter elements with care and hold them only by the edges.

Set the filter (Fig. 5/1) with the seal (Fig. 5/2) facing upwards into the clamping frame and push it in up to the rear travel stop.

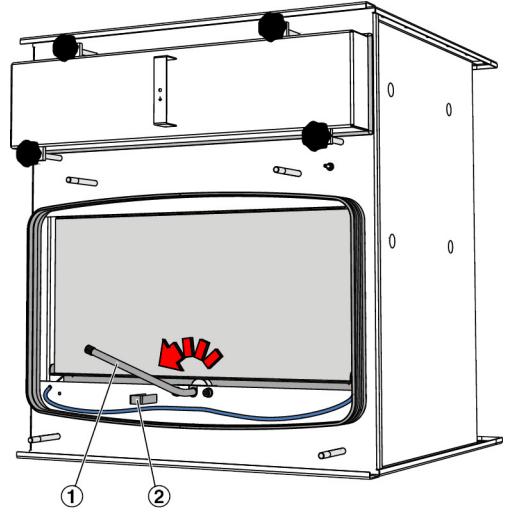

Fig. 6: Pressing the filter on

5. ▶ Press the filter seal against the sealing integrity test groove using the clamping frame. Then turn the operating lever (Fig. 6/1) anti-clockwise to the travel stop (Fig. 6/2).

**IMPORTANT** The clamping frame can be tensioned only when the filter is correctly positioned.

6. ▶ **EX EXPLOSION HAZARD!**  
KSFS-...-Ex: Connect the earthing cable to the filter element with the blade connector (Fig. 2/3).

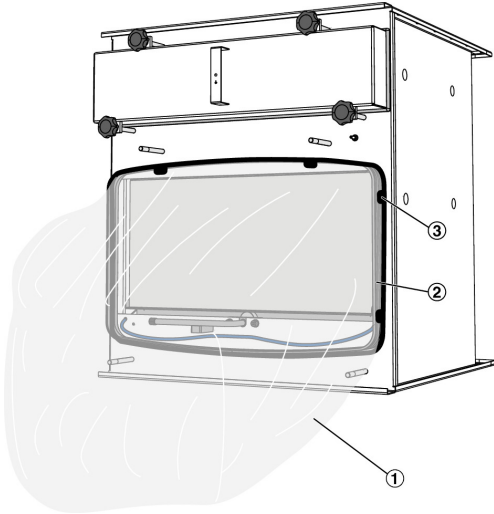

Fig. 7: Attaching the maintenance sack

- 7. ▶ Put the maintenance sack (Fig. 7/1) over the service board (Fig. 7/2) and fasten it in the first groove with the clamping ring (Fig. 7/3).

- 8. ▶ Roll up the maintenance sack and place it in front of the particulate filter element.

Note: When rolling up the maintenance sack, make sure that the ends of the sack do not protrude over the service board.

- 9. ▶ Close the filter casing with the filter chamber cover in the reverse order of step 1. Screw the clamping screws hand-tight using the star grip.

**IMPORTANT** The casing cover can only be mounted when the clamping frame is tensioned.

- 10. ▶ Once you have inserted the filter, check the sealing test groove, ☞ 'Sealing integrity test' on page 14.

- 11. ▶  **EXPLOSION HAZARD!**  
KSFS-...-Ex: Mount the earthing cable from the filter chamber cover (Fig. 2/2).



## Maintenance

Maintenance applies mainly to the filter element. Check the filter regularly and replace it, if necessary.

The service life of a filter depends mainly on how polluted the air is. Check the filter in intervals that are short enough so that you can anticipate any defects or problems before they actually occur.

Replace the filter immediately if any of the following is true:

- The reaching of the intended final differential pressure
- Hygiene problems (micro-organisms, fungal spores, odours, etc.)
- Filter defects (particle count has been exceeded)
- The maximum filter usage time has been reached (8 years, to VDI 3803, part 4).



*You may replace a filter even before the defined final differential pressure has been reached if it is more economic.*

## Changing the filter

### Personnel:

- Properly trained person

### Protective equipment:

- Industrial safety helmet
- Light respiratory protection
- Protective gloves

**Note:** The change of the filter is described using the main filter as an example; the change of the prefilter is identical. For clarification, handling without the maintenance sack (for a low-contamination filter change) is described. Handling of the maintenance sack ↻ 'Handling of the maintenance sack (low-contamination filter change)' on page 13.

- Do not unpack filter elements until you are ready to install them.
- Do not touch the filter area; hold the filter by the edge only.
- Check filter elements for any damage; replace damaged filter elements.
- Insert only suitable Mini Pleat filters with a flat seal.



### EXPLOSION HAZARD!

*Switch off the air conditioning system before changing the filter, if necessary rinse with fresh air beforehand.*

### 1. ▶



### EXPLOSION HAZARD!

*KSFS-...-Ex: Remove the earthing cable from the filter chamber cover (Fig. 2/2).*

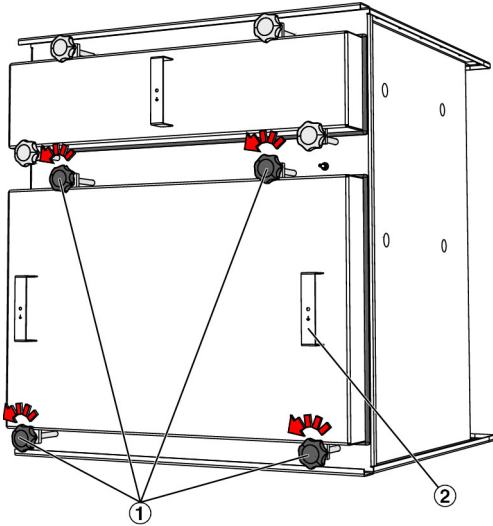

Fig. 8: Opening the cover

2. ▶ Unscrew the clamping screws (Fig. 8/1) on the cover using the star grip. Remove the cover from the casing by both handles (Fig. 8/2) and store it.

3. ▶ **EXPLOSION HAZARD!**  
KSFS...-Ex: Remove the earthing cable from the filter element (blade connector Fig. 2/3).

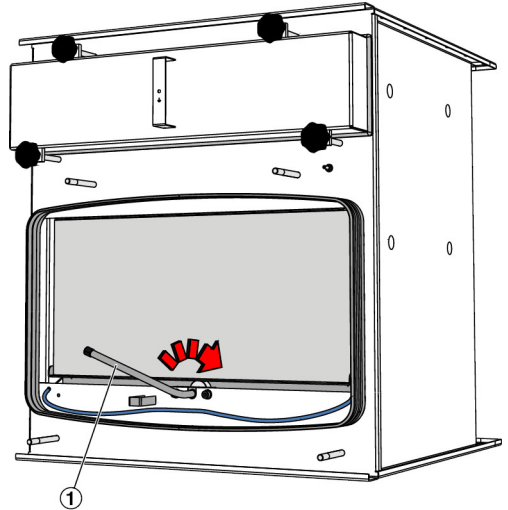

Fig. 9: Releasing the clamping frame

4. ▶ Release the clamping frame by turning the operating lever (Fig. 9/1) clockwise.

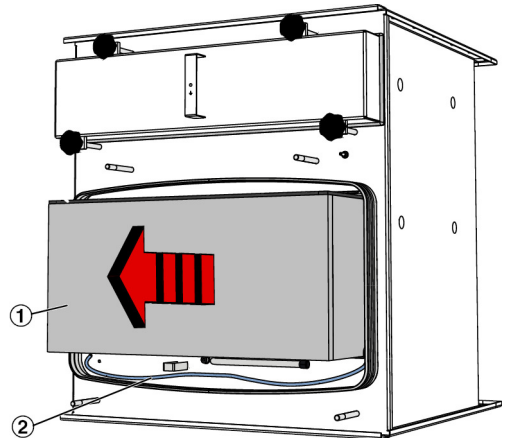

Fig. 10: Removing the filter

5. ▶ Loosen the filter (Fig. 10/1) from the sealing surface using the extraction device (Fig. 10/2) and remove it from the filter casing towards the front.

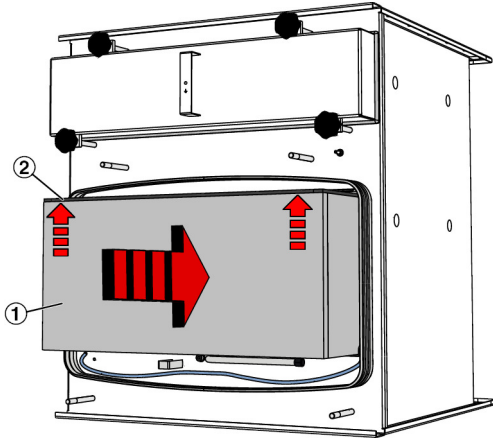

Fig. 11: Filters, inserting

6. ▶

**! NOTICE!**

**Do not damage the filter.**

Handle filter elements with care and hold them only by the edges.

Set the filter (Fig. 10/1) with the seal (Fig. 10/2) facing upwards into the clamping frame and push it in up to the rear travel stop.

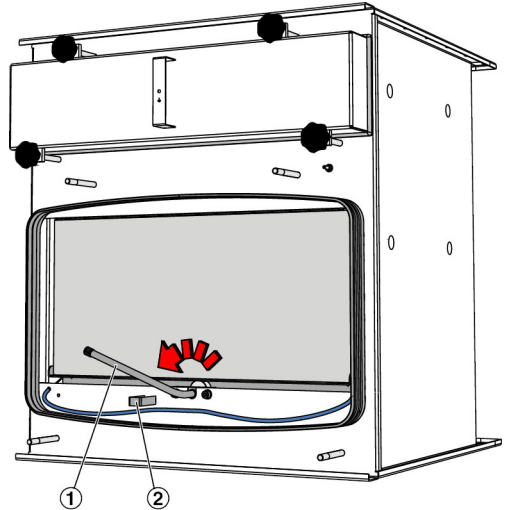

Fig. 12: Pressing the filter on

7. ▶ Press the filter seal against the sealing integrity test facility using the clamping frame. Then turn the operating lever (Fig. 12/1) anti-clockwise to the travel stop (Fig. 12/2).

**IMPORTANT** The clamping frame can be tensioned only when the filter is correctly positioned.

8. ▶ After inserting the filter, perform the sealing integrity test, ☞ 14.

9. ▶

**⚡ EXPLOSION HAZARD!**

KSFS-...-Ex: Connect the earthing cable to the filter element with the blade connector (Fig. 2/3).

Only required for low-contamination filter changes:

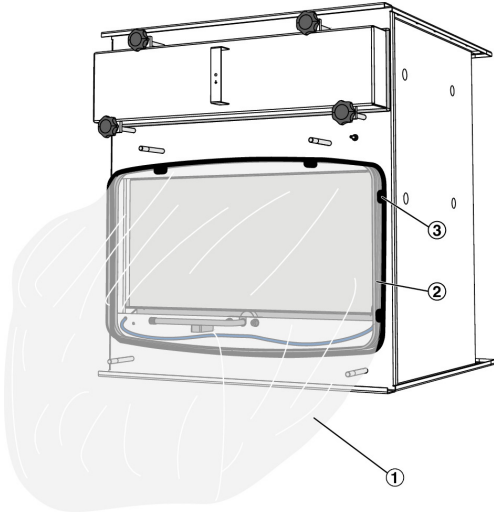

Fig. 13: Attaching the maintenance sack

10. ▶ Put the maintenance sack (Fig. 13/1) over the service board (Fig. 13/2) and fasten it in the first groove with the clamping ring (Fig. 13/3).
11. ▶ Roll up the maintenance sack and place it in front of the particulate filter element.

Note: When rolling up the maintenance sack, make sure that the ends of the sack do not protrude over the service board.

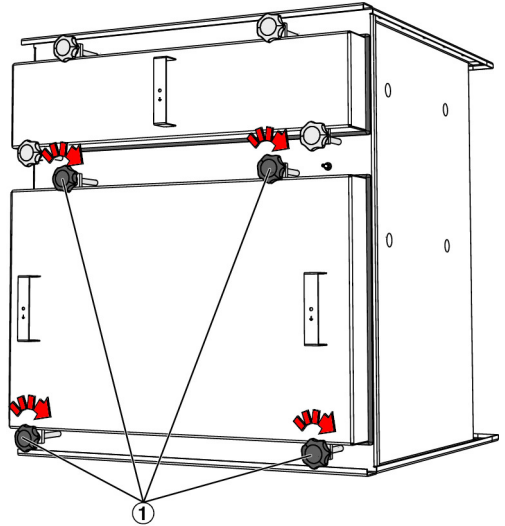

Fig. 14: Closing the casing

12. ▶ Place the cover on the filter casing, and tighten the star knob screws (Fig. 14/1) hand-tight.

**IMPORTANT** The casing cover can only be mounted when the clamping frame is tensioned.

13. ▶



**EXPLOSION HAZARD!**

*KSFS-...-Ex: Mount the earthing cable from the filter chamber cover (Fig. 2/2).*

**Handling of the maintenance sack (low-contamination filter change)**

**EXPLOSION HAZARD!**

Switch off the air conditioning system before changing the filter, if necessary rinse with fresh air beforehand.

1. ▶

**EXPLOSION HAZARD!**

KSFS-...-Ex: Remove the earthing cable from the filter chamber cover (Fig. 2/2).

2. ▶ Open the cover, Fig. 8.

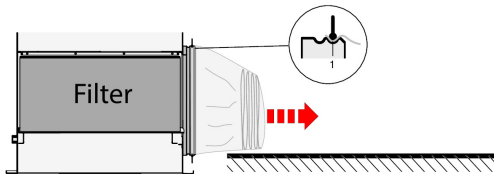

3. ▶ Pull the maintenance sack out of the casing.

4. ▶

**EXPLOSION HAZARD!**

KSFS-...-Ex: Remove the earthing cable from the filter element (blade connector Fig. 2/3).

5. ▶ Release the clamping frame, Fig. 9.

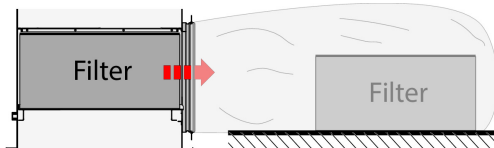

6. ▶ Pull the filter out of the casing and put it directly into the maintenance sack.

**EXPLOSION HAZARD!**

KSFS-...-Ex: Use the welding device only if there is no potentially explosive atmosphere.

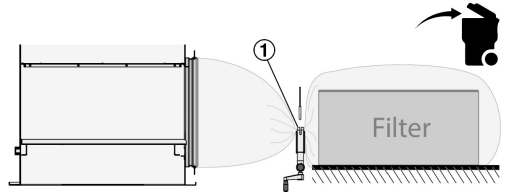

7. ▶ Weld off the maintenance sack with the welding device (accessory).

Properly dispose of the filter.

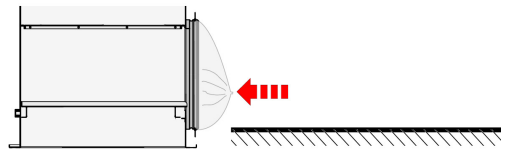

8. ▶ Rolling the maintenance sack up to the filter casing

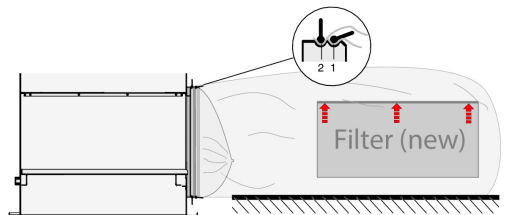

9. ▶ Insert the new filter into a new maintenance sack and put the maintenance sack into groove 2 over the old maintenance sack. Observe the position of the filter seal.

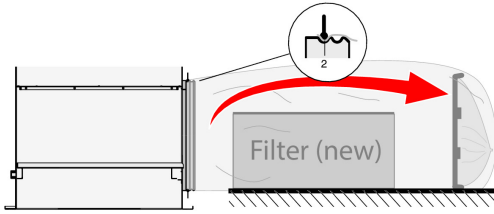

- 10. ▶ Remove the old maintenance sack from groove 1 and place it behind the new filter.

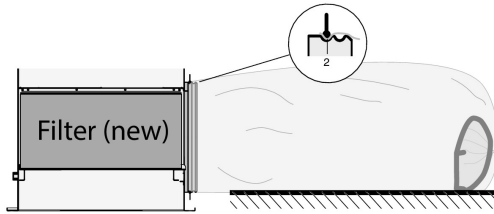

- 11. ▶ Pushing the new filter into the casing

- 12. ▶ Press the filter on, Fig. 12.

- 13. ▶ 

**EX** **EXPLOSION HAZARD!**

*KSFS-...-Ex: Connect the earthing cable to the filter element with the blade connector (Fig. 2/3).*

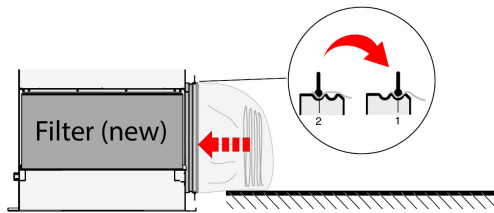

- 14. ▶ Move the maintenance sack with the ring seal from groove 2 onto groove 1. Roll up the maintenance sack and place it in the casing.

- 15. ▶ Close the casing, Fig. 14.

- 16. ▶ 

**EX** **EXPLOSION HAZARD!**

*KSFS-...-Ex: Mount the earthing cable from the filter chamber cover (Fig. 2/2).*

**Sealing integrity test**

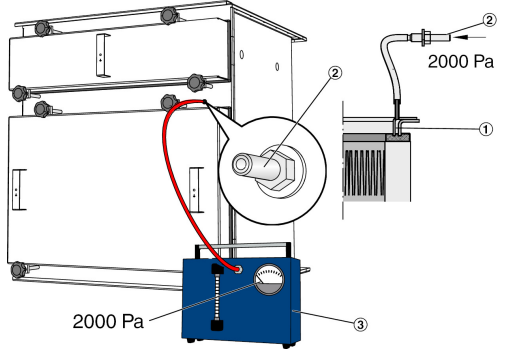

Fig. 15: Sealing integrity test

The casing is fitted with a sealing integrity test facility. Sealing integrity is tested with a sealing integrity test device (see operating manual).

- 1. ▶ Connect the sealing integrity test device (Fig. 15/3) to the connection point on the filter (Fig. 15/2).
- 2. ▶ Apply at least 2000 Pa to the test groove (Fig. 15/1).
- 3. ▶ Check the leakage rate on the flow rate meter of the sealing integrity test device.
  - ⇒ The value must not exceed 0.003% of the nominal volume flow rate.

If this value is exceeded, adjust the clamping screws or the clamping frame; also check the seal, test groove and filter element for damage. Then repeat the sealing integrity test.

## Differential pressure measurement

The initial differential pressure for TROX filters is given on the label on the filter frame.

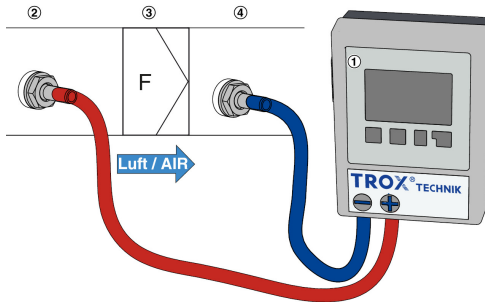

Fig. 16: TROX MD-DPC connection

For optimum filter monitoring, we recommend continuous differential pressure measurement and monitoring of the final differential pressure. The measurement is carried out using a permanently installed differential pressure measuring device (Fig. 16/1), e.g. TROX MD-UT, MD-APC or MD-DPC, using the pressure measurement points (Fig. 16/2 and 4) on the duct.

Alternatively, filter monitoring is also possible with close-meshed, temporary differential pressure measurements.

Connecting a measuring device

- Plus (+) - Upstream of the filter (3) at measurement point (2)
- Minus (-) - Downstream stream of the filter (3) at measurement point (4)

In the case of temporary measurement, reattach the plugs at the measurement points after the measurement.

## Disposal

### ENVIRONMENT!

Risk of harm to the environment due to the incorrect handling of hazardous materials and substances.

Filters and cleaning materials that have been contaminated with bacterial, toxic or radioactive particles are considered hazardous waste and have to be disposed of by an authorised business in compliance with local regulations.

Disposing of filter elements with household waste is allowed only in the following cases:

- For unused filter elements
- For filter elements that have been exposed only to atmospheric outdoor air

## Ordering replacement filters

To ensure permanent protection from particulate matter and other pollutants we recommend using only original TROX filters.

Original TROX filters carry a sticker on the frame with both the use before date and information on how to order replacements.



*To avoid downtime of the ventilation and air conditioning system, we recommend you to always have the required filters in stock.*

To order filters go to: [www.troxtechnik.com](http://www.troxtechnik.com)

## Cleaning the filter casing

### Personnel:

- Properly trained person

### Protective equipment:

- Light respiratory protection

It is usually not possible to regularly clean and disinfect the ductwork between the second filter stage and the filter casing, and neither is it required for hygienic reasons. As a prerequisite, however, you have to keep the ducts clean during installation.

It is then sufficient to clean and disinfect (wipe) the filter casing and the diffuser face; this has to be done for the first time just before the ventilation and air conditioning system is switched on for the first time.

The casing may be cleaned with a damp cloth. Sticky dirt or contamination may be removed with a commercial, non-aggressive cleaning agent. Cleaning agents that contain chlorine must not be used.

Once you have completed cleaning, disinfect the filter casing and any connecting rooms.