



Centrifugal fans

REH; RZH; BVREH; BVRA

Fire gas versions checked according to EN 12101-3



Read the instructions prior to performing any task!

TROX X-FANS GmbH

Heinz Trox Str. 1

36251 Bad Hersfeld, Germany

Telephone: +49 6621/950-0

Fax: +49 6621/950-100

email: info-xfans@trox.de

Internet: www.trox-xfans.de

1925113, 1, GB/en

08/2019

© 2018

12	Index	44
	Appendix	46
	A Commissioning report.....	47
	B Maintenance report.....	49
	C Tables.....	52
	D Installation manuals.....	55

1 General

1.1 About this manual

This manual enables safe and efficient working with the unit. The manual must be kept near the unit to be available for use at all times. It is essential that these individuals read and fully understand this manual before starting any work. The basic prerequisite for safe working is to comply with the safety notes and all instructions in this manual. The local regulations for health and safety at work and general safety regulations also apply. Illustrations in this manual are mainly for information and may differ from the actual unit design.

In addition to this manual, the operating manuals of the integrated components in the appendix also apply. The instructions in the manuals – particularly safety notes – must be observed!

1.2 Explanation

Safety notes

Symbols are used in this manual to alert readers to areas of potential hazard. Signal words express the degree of the hazard.

Comply with all safety instructions and proceed carefully to avoid accidents, injuries and damage to property.

DANGER!

Imminently hazardous situation which, if not avoided, will result in death or serious injury.

WARNING!

Potentially hazardous situation which, if not avoided, may result in death or serious injury.

CAUTION!

Potentially hazardous situation which, if not avoided, may result in minor or moderate injury.

EXPLOSION HAZARD!

Failure to comply with these notes leads to loss of explosion protection and may result in serious injury and death.

NOTICE!

Potentially hazardous situation which, if not avoided, may result in property damage.

ENVIRONMENT!

Environmental pollution hazard.

Tips and recommendations



Useful tips and recommendations as well as information for efficient and fault-free operation.

Specific safety notes

The following symbols are used in safety notes to alert you to specific hazards:

Warning signs	Type of danger
	Warning – high-voltage.
	Warning – suspended load.
	Warning – danger zone.

Other markers

The following markers are used to highlight instructions, results, lists, references and other elements in this manual:

Marker	Explanation
 1., 2., 3. ...	Step-by-step instructions
	Results of actions
	References to sections in this manual and to other applicable documents
	Lists without a defined sequence
[Push button]	Control elements (e.g. push buttons, switches) or display elements (e.g. LEDs)
'Display'	Screen elements (e.g. buttons or menus)

1.3 Limitation of liability

The information in this manual has been compiled with reference to the applicable standards and guidelines, the state of the art, and our expertise and experience of many years.

The manufacturer does not accept any liability for damages resulting from:

- Non-compliance with this manual
- Incorrect use
- Operation or handling by untrained individuals
- Unauthorised modifications
- Technical changes
- Use of non-approved replacement parts



Please observe our commissioning and maintenance instructions in Chapters 6 'Installation and commissioning' on page 27 and 9 'Maintenance' on page 38.

The actual scope of delivery may differ from the explanations and illustrations provided in this manual for special versions, the use of additional order options or as a result of recent technical changes. The obligations agreed in the order, the general terms and conditions, the manufacturer's terms of delivery, and the legal regulations in effect at the time the contract is signed shall apply. We reserve the right to make technical changes.

1.4 Copyright

This manual is protected by copyright and is exclusively for use in your company by authorised personnel. Violators will be held liable for any damage. The right to further claims remains reserved.

1.5 Replacement parts



WARNING!

Safety risk caused by incorrect replacement parts!

Counterfeit or faulty replacement parts may affect safety, and cause damage, malfunctions or total failure.

Therefore:

- Only use original replacement parts provided by the manufacturer.

Buy replacement parts from an authorised supplier or from the manufacturer. See address on page 2.

The lists of replacement parts can be found in Chapter 11 'Lists of replacement parts' on page 43.

1.6 Liability for defects

The provisions on liability for defects are described in *Point VI* of the General Terms of Delivery and Payment. The provisions can be viewed on our website at www.trox-xfans.de under "Delivery and payment terms".

1.7 Customer service

Our customer service team is available to provide any technical information. Information about the responsible contact person is always accessible over the phone, by fax, by email or over the Internet; see the manufacturer's address on page 2. We offer the following services:

- Assembly, commissioning and maintenance of the fans
- Measurement, analysis and evaluation of all the data required for operation (e.g.: pressure, volume, sound, vibrations)
- Operational balancing
- Replacement parts service
- Individual advice and help placing orders

2 Safety

This section provides an overview of all the important safety issues for the best possible protection of personnel as well as for safe and fault-free operation. Failure to comply with the instructions and safety notes listed in this manual can lead to serious hazards.

2.1 System owner's responsibility

The unit is intended for commercial use. The system owner is therefore subject to the legal obligations of occupational health and safety regulations. In addition to the safety notes in this manual, the applicable regulations for safety, accident prevention and environmental protection must also be complied with. In particular:

- The system owner must be aware of the applicable occupational health and safety regulations and carry out a risk assessment to determine any additional hazards that may exist or result from the specific working conditions at the installation location of the unit. The system owner has to create operating instructions for the unit that reflect the results of this risk assessment.
- The system owner must ensure, throughout the unit's entire operating period, that the operating instructions they create comply with the applicable standards and guidelines and must adapt them as required.
- The system owner must clearly regulate and define the responsibilities for assembly / installation, operation, maintenance and cleaning.
- The system owner has to ensure that all individuals who handle or use the unit have read and understood this manual.
The system owner must regularly provide training for the personnel and inform them of any dangers.
- The system owner must provide the employees with the required personal protective equipment.

The system owner is also responsible for ensuring that the unit is always in a technically perfect condition. The following therefore applies:

- The system owner must ensure that the maintenance intervals specified in this manual are observed.
- The system owner must have all safeguards tested regularly to ensure that they are functional and complete.

2.2 Personnel requirements

2.2.1 Qualifications



WARNING!

Danger of injury due to insufficiently qualified individuals!

Incorrect use may cause considerable injury or damage to property.

Therefore:

- Only specialist personnel must carry out work.

The following degrees of qualification are required for the work described in the operating manual:

Instructed person

The instructed person has been certifiably instructed by the system owner with regard to the tasks delegated to them and potential hazards in the event of inappropriate behaviour.

Instructed person

The instructed person has been instructed by the system owner with regard to the tasks delegated to them and potential hazards in the event of inappropriate behaviour.

Skilled qualified electrician

Skilled qualified electricians are individuals who have sufficient professional or technical training, knowledge and actual experience to enable them to work on electrical systems, understand any potential hazards related to the work under consideration, and recognise and avoid any risks involved.

The qualified electrician is trained especially for the field in which they work and is familiar with the relevant standards and regulations.

Specialist personnel

Specialist personnel are individuals who have sufficient professional or technical training, knowledge and actual experience to enable them to carry out their assigned duties, understand any potential hazards related to the work under consideration, and recognise and avoid any risks involved.

Only persons who can be expected to perform their work reliably are acceptable as personnel. Individuals whose reaction time is delayed due to alcohol, drugs or other medication must not carry out any work.

- The age-specific and occupational regulations applicable at the operation site must be observed when appointing personnel.

2.2.2 Unauthorised persons

WARNING!

Danger for unauthorised persons!

Unauthorised persons who do not fulfil the requirements specified here are usually not aware of the dangers in the work area.

Therefore:

- Keep unauthorised persons away from the work area.
- Instruct these persons to leave the hazardous area or work area.
- Stop work while unauthorised persons are present in the work area.

2.3 Correct use

The unit is only designed and constructed for the intended use described here.

- The ventilation fan is only designed to convey normal, dust-free and conditioned air, and other non-aggressive, non-explosive gases.
- The smoke exhaust fan is also designed to convey fire gases in accordance with its temperature and time specifications.

Replace fan after use in the event of a fire!

- The explosion-proof fan is designed to convey explosive media and/or for installation in potentially explosive atmospheres according to its labelling.

Other intended uses approved by the manufacturer and derived from the optional fan equipment are detailed in the customer specifications.

WARNING!

Danger due to incorrect use!

Any use that extends beyond the correct use and/or different use of the unit can lead to hazardous situations.

Therefore:

- Only use the unit for its correct use.
- Strictly comply with all of the information in this operating manual.

Claims of any type for damages resulting from incorrect use will not be accepted.

The system owner is solely responsible for all damages resulting from incorrect use.

2.4 Explosion protection

ATEX Product Directive 2014/34/EU (ATEX 95)

The aim of the Directive is to protect individuals who work in potentially explosive atmospheres. The Directive contains the essential health and safety requirements that the manufacturer must observe and that must be verified by means of appropriate conformity assessments. Since 30 June 2003, only units, components and protective systems which comply with the ATEX Product Directive 2014/34/EU can be used.

The deliverable version options are highlighted below:

Equipment groups

Equipment group	For use in....
I	Units for use in mining
II	Units for use in the other areas

Classification

Zone	Category	EPL	Safety
0	1	Ga	Very high level of safety
1	2	Gb	High level of safety
2	3	Gc	Normal operation

Atmosphere

G = Gases

D = Dusts

Explosion group (gas group)

Gases and vapours are split into three explosion groups (IIA, IIB and IIC) based on their particular flammability. The danger increases from explosion group IIA to IIC. (The higher explosion group includes the lower ones.)

Temperature class

Six temperature classes (T1 to T6) have been defined for the permissible surface temperatures. Certain combustible gases and vapours can be assigned to these temperature classes based on the relevant ignition temperatures.

The following table provides an overview of the maximum permissible surface temperatures on the units and some associated gases that apply to the temperature classes.

Group	Temperature class (surface temperature)					
	T1 (<450°C)	T2 (<300°C)	T3 (<200°C)	T4 (<135°C)	T5 (<100°C)	T6 (<85°C)
I	Methane					
IIA	Ammonia methanol	n-butyl alcohol n-butane	Benzine diesel / heating oil	Acetaldehyde		
IIB	Town gas	Ethylene alcohol elthy- lene		Ethyl ether		
IIC	Hydrogen	Acetylene				Carbon disul- phide

Correct use

Fans designated as “explosion-proof” are subject to the legal requirements in force with regard to the Explosion Protection Regulation and Directive 2014/34/EU. They are part of equipment group II and are suitable for conveying class IIA and IIB gases from zones 1 and 2. The fans are also suitable for installation in an explosive atmosphere in the above-mentioned zones.

Marker

In accordance with Directive 2014/34/EU – known as ATEX 95 – only units that conform to this Directive can be used in potentially explosive atmospheres since 1 July 2003.

The fans are suitable for conveying potentially explosive media and/or for installation in rooms with potentially explosive media.

Special provisions according to ‘Commissioning report’ on page 47 and ‘Maintenance report’ on page 49 must be observed during commissioning and maintenance.

EXPLOSION HAZARD!

Unit components that comply with Directive 2014/34/EU include additional information on the rating plate.



Fig. 1: Marking according to ATEX

- CE mark
- Unit is certified for Ex area.
- II Equipment group (not for use in mining)
- 2G Unit category and atmosphere
- h Type of protection (non-electrical)
- IIB Gas group
- T4 Temperature class
- Gb EPL (equipment protection level)

Operating conditions

WARNING!

The inlet temperature of the flow medium must be between -20°C and +40°C. The manufacturer must be consulted if higher temperatures are required.

WARNING!

The maximum operating speed specified on the fan rating plate must be observed.

Vibration monitoring



It is recommended that the system owner install a permanent vibration monitoring system to prevent sparks from being generated as a result of the impeller striking against parts of the casing following imbalance during operation. A permanent vibration monitoring system is obligatory if mist or dust is being conveyed.



EXPLOSION HAZARD!

Ignition sources, such as sparks, naked flames and hot surfaces, can lead to explosions in potentially explosive atmospheres. The following therefore applies to all work on units in the Ex area:

- *Get written permission before you start the work.*
- *Only perform work if there are no dust deposits or a potentially explosive atmosphere.*
- *Use only tools that have been approved for use in areas with potentially explosive atmospheres.*

Additionally:

- *It must be ensured that sufficient cooling air is supplied to the fan drive motor at all times.*
- *Motors with a cover must be used if fans with a vertical motor shaft are installed.*
- *Servicing and maintenance work on explosion-proof fans must only be carried out by qualified personnel with the relevant explosion protection qualifications using original replacement parts*

Failure to comply with these notes leads to loss of explosion protection and may result in serious injury and death.



EXPLOSION HAZARD!

If a component or device is to be installed in a system intended for use in potentially explosive atmospheres according to 2014/34/EU, the system owner has to ensure compliance of the entire system with that directive. Non-compliance may lead to an explosion.

2.5 Personal protective equipment

Personal protective equipment must be worn for any work in order to reduce health or safety hazards to the minimum.

- Wear the protective equipment necessary for the respective work for as long as the work takes.
- Observe instructions relating to personal protective equipment that are displayed in the work area.

Special protective equipment is required when carrying out specific work. This is referred to separately in the individual chapters of this manual.

Hearing protection



To prevent hearing damage.

Protective clothing



is close fitting, with low tear resistance, close fitting sleeves, and no projecting parts. It prevents entanglement in moving machinery. Do not wear rings, chains or any other jewellery.

Protective gloves



Protective gloves are used to protect hands from friction, abrasions, punctures, deep cuts and direct contact with hot surfaces

Safety helmet



for protection from falling and flying parts and materials.

Safety shoes



for protection from heavy, falling parts and from slipping on slippery surfaces.

2.6 Specific hazards

Electric current

DANGER!

Danger of death due to electric current!

Danger of electric shock! Do not touch any live components! Damaged insulation or damaged parts are a life threatening hazard.

- Have work on the electrical system carried out only by skilled qualified electricians.
- If the insulation is damaged, disconnect the power supply immediately and have the insulation repaired.
- Before you start working on electric systems and equipment, switch off the supply voltage and secure it against being switched on accidentally. Comply with the 5 safety rules:
 - Disconnect.
 - Secure it against being switched on accidentally.
 - Ensure that no voltage is present.
 - Connect to the earth; short circuit connection.
 - Either cover nearby parts that carry a voltage or install barriers.
- Do not bypass or disable any circuit breakers. Be sure to maintain the correct current rating when you replace a circuit breaker.
- Ensure that live parts do not come into contact with moisture. Moisture can cause a short circuit.

Noise

WARNING!

Hearing damage due to noise!

The noise level in the work area can cause severe hearing damage.

- Always wear hearing protection while working.
- Only remain in the hazardous area if absolutely necessary.

Moving components

WARNING!

Risk of injury due to moving components!

Moving components can cause serious injuries.

- Do not reach into or handle moving components during operation.
- Never open covers during operation.
- The fan does not stop immediately! Check that no components are moving before you open the covers.
- Wear tight-fitting clothing with low tear resistance in the hazardous area.

Rotating parts

WARNING!

Risk of injury from rotating parts!

Rotating parts in the fan can cause serious injuries.

- Do not reach into or handle the moving impeller wheel during operation.
- Do not open covers and maintenance covers during operation.
- Ensure that the impeller wheel is not accessible during operation.
- The fan does not stop immediately! Ensure that none of the components are still moving before opening the covers for maintenance purposes.
- Switch off the unit and secure it against being switched back on again before starting any work on moving fan components. Wait until all parts have come to a standstill.

Vibrations

WARNING!

Risk of injury due to strong vibrations!

Strong vibrations can result in serious injury and chronic health impairments in the long term. The source of the vibration can be decoupled from the surrounding area using a vibration damper.

- Do not deactivate the vibration damper.
- Do not remain in the vibrating area during operation.

Suspended loads



DANGER!

Danger of death due to suspended loads!

Falling loads may cause serious injury or death.

Therefore:

- Never walk under suspended loads.
- Only move loads under supervision.
- Observe the specifications for the intended lashing points.
- Do not attach the lifting gear to protruding machine parts or lugs on attached components
- Ensure that the lifting gear is secure.
- Only use approved hoisting devices and lifting gear with with sufficient load-bearing capacity.
- Do not use any frayed or worn ropes and belts.
- Do not place ropes or belts near sharp edges or corners; do not knot or twist.
- Place the load on the ground before leaving the workplace.



IMPORTANT!

For further information on the position of the safeguards, see Chapter 4 'Parts and function' on page 21.

Isolator (optional)



Fig. 2: Isolator

Some fans are equipped with an isolator.

Falling materials



WARNING!

Risk of injury due to falling materials!

During operation, material can fall in an uncontrolled manner or be ejected and cause serious injuries.

- Do not enter the hazardous areas during normal operation.
- Wear an industrial safety helmet, safety shoes and protective clothing when entering the hazardous area (e.g. during setting mode).



WARNING!

Danger of death due to uncontrolled reactivation!

Uncontrolled reactivation can lead to serious personal injury or death!

Therefore:

- Before reactivation, ensure that all of the safeguards are assembled and fully functional.
- Ensure that nobody is in the hazardous area.

2.7 Safeguards



WARNING!

Risk to life from defective safeguards!

Safety is only assured if the safeguards are intact.

Therefore:

- Before starting work, check whether the safeguards are fully functional and installed correctly.
- Never deactivate safeguards.
- Ensure that safeguards such as the emergency stop push-button, trip cords, etc., are accessible at all times.

Secured isolator



Fig. 3: Secured isolator

The isolator can be locked in the “0” position with a padlock to prevent reactivation.

Additional smoke exhaust fan option

The isolator can also be locked in the “1” position with a padlock to prevent deactivation in order to guarantee the smoke extract function.

⚠ DANGER!

Danger of death due to impermissible activation and deactivation!

Individuals can enter the hazardous area if the isolator has been locked with a padlock to prevent activation. Activation could cause life-threatening injuries to these individuals.

If the fan has been secured with a padlock to prevent it from being deactivated, it can be equipped with an automatic start-up feature in the event of a fire. Deactivation ensures that the fan is not ready for operation in the event of a fire and cannot transport fire gases.

Therefore:

- Never remove the padlock without authorisation.
- Before removing the padlock, ensure that there are no more individuals in the hazardous area.

Integration in an emergency stop concept required

The unit is designed for use within a system. It does not have its own control and there is no autonomous emergency stop function.

Before the unit is started up, install emergency stop equipment for the unit and connect it to the system control's safety chain.

This does not apply to smoke exhaust fans.

Connect the emergency stop equipment in such a way that any hazardous situations for individuals and property are excluded in the event of the power supply being interrupted or the power supply being activated following an interruption.

The emergency stop equipment must be freely accessible at all times.

2.8 Behaviour in the event of hazardous situations or accidents

Preventative measures

- Always be prepared for accidents or fire!
- Keep first aid equipment (first aid kit, blankets, etc.) and fire extinguishers close at hand.
- Familiarise personnel with accident reporting, first aid and rescue equipment.
- Keep access paths for rescue vehicles clear.

Measures in the event of accidents

- Trigger an emergency stop immediately, and put the isolator into the “0” position if necessary.
- Implement first aid measures.
- Rescue individuals from the hazardous area.
- Inform the responsible person at the operation site.
- Notify the emergency services.
- Clear access paths for rescue vehicles.

2.9 Labelling

The following symbols and signs are usually found in the work area. They apply to the very location where they are found.

⚠ WARNING!

Risk of injury due to illegible symbols!

Over time, stickers and signs can become dirty or otherwise illegible.

Therefore:

- Ensure that all of the safety, warning and operating information is clearly legible.
- Replace illegible signs or stickers immediately.



Fig. 4: Terminal box

The (Fig. 4/1) “Danger of death due to electric current” symbol is attached to the terminal box.

3 Technical data

3.1 Design versions

IMPORTANT!

By selecting the construction style, each centrifugal fan is adjusted to the requirements at the operation site. Additional options available upon request.

3.1.1 Type codes for centrifugal fans

The type code is a distinctive and unique product designation. All of the technical data of the product in the TROX X-FANS catalogue or product configurator can be accessed with this code.

BV REH 710 R LG 90

Fig. 5: Type code for centrifugal fan

- BV Smoke exhaust fan (fire gas),
- R Centrifugal fan
- Z E = single inlet; Z = double inlet
- H High-performance impeller
- 710 Nominal size
- R R = with belt drive; M3 = heavyweight construction, directly driven; B-M = lightweight construction, directly driven
- LG LG = anticlockwise; RD = clockwise
- 90 Casing orientation 0°, 90°, 180°, 270°

3.1.2 Additional labelling

The temperature classification of smoke exhaust fans (BV) is based on EN 12101-3:

- F200 = temperature of 200°C, minimum operating time of 120 minutes
- F300 = temperature of 300°C, minimum operating time of 60 minutes
- F400 = temperature of 400°C, minimum operating time of 90/120 minutes
- F600 = temperature of 600°C, minimum operating time of 60 minutes
- F842 = temperature of 842°C

3.2 Series

3.2.1 Type REH-M3



Fig. 6: Type REH-M3

3.2.2 Type REH-B-M



Fig. 7: Type REH-B

3.2.3 Type REH-R



Fig. 8: Type REH-R

3.2.4 Type RZH

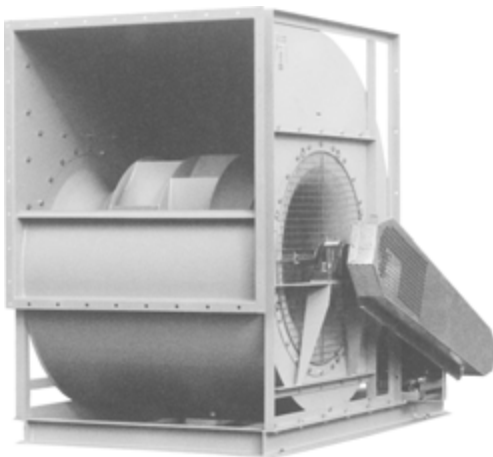

Fig. 9: Type RZH

3.2.5 Type BVREH



Fig. 10: Type BVREH

3.2.6 Type BVRA



Fig. 11: Type BVRA

3.3 Connection values

The connection values are dependent on the type of electric motor that is installed (rating plate of electric motor, see § 3.7 'Rating plate' on page 20).

3.4 Noise emission values

The characteristic noise values of the fans are specified in the characteristic curve sheets in the catalogue/ product configurator. The characteristic values are dependent on the operating point.

3.5 Operating conditions

Type REH/RZH

Data	Value	Unit
Min./max. flow medium temperature	-20/+60	°C
Min./max. ambient temperature	-20/+60	°C
Max. operating time according to EN 60034-1	24	hrs/day
Smoke extract	None	-
Installation	horizontal	-

Type BVREH/BVRA

Data	Value	Unit
Min./max. flow medium temperature	-20/+60	°C
Min./max. ambient temperature	-20/+60	°C
Max. operating time according to EN 60034-1	24	hrs/day
Smoke extract	2)	-
Installation	horizontal	-

2) Temperature/time category according to EN 12101-3 (see § 3.1 'Design versions' on page 16)

ATEX

Data	Value	Unit
Min./max. flow medium temperature	-20/+40 ³⁾	°C
Min./max. ambient temperature	-20/+40	°C
Max. operating time	24	hrs/day
Smoke extract	None	-
Installation	horizontal	-

3) Other values upon request

3.5.1 Information on setting up fans that are installed outdoors

3.5.1.1 Penetration of precipitation

3.5.1.2 Formation of condensation

3.5.1.3 Stability

3.5.1.4 Penetration of foreign matter

3.6 Operating modes

3.6.1 S1 continuous operation

The fans are designed for continuous operation (S1 operating mode according to DIN EN 60034-1).

3.6.2 S9 speed-controlled operation

General

Fans are speed-controlled to adjust the operating point to the system and utilisation requirements.

Speed control, maximum speed

The maximum speed specified on the rating plate must not be exceeded.

Measures in the case of natural frequencies

Mechanical components have natural frequencies that can cause the components to fail if accelerated to impermissibly high vibrations. There is a possibility that casing parts, bearings, crankshafts, attachments and impellers can be damaged.

Excitation frequencies are, for example, caused by the impeller's rotary frequency, the blades' frequency, the blades' rotational frequency, the motor's rotary frequency or aerodynamically.

If the excitation frequency is exactly or practically the same as a component's natural frequency, resonance frequencies that can cause the component to fail will occur. The excitation forces are dependent on the components' balancing condition, true running characteristics, aerodynamic forces and damping features.

DANGER!

Danger due to resonance frequencies!

The fan must not be operated in the higher speed range in which increased vibration values occur. These areas must be skipped or removed for the operation. The areas must be passed through so quickly that the permissible vibration values in the resonance frequency are not engaged or exceeded.

A permanent vibration monitoring system is recommended for speed-controlled fans to ensure the long-term, safe operation of the fan.

After commissioning speed-controlled fans, it is common practice to initially start them with short maintenance intervals, and if no damage occurs, to gradually adjust the maintenance intervals to the intervals specified in the operating manual.

Commissioning of speed-controlled fans

During commissioning, the fan vibrations must be checked over the entire speed control range of the fan. During this process, the vibrations on the casing and bearing must be determined and evaluated in accordance with DIN ISO 14694 depending on the installation and motor rating. Refer to the "Vibration velocities" table in the appendix of the operating manual for the permissible vibration velocities. ↪ *Appendix 'Tables' on page 52*

The amplitude of the vibration velocities is dependent on different factors.

The type of installation, the upstream and downstream conditions, the characteristics of the supporting structure/foundation, fan operating point, attachments and accessories influence the quiet running of the machine and can therefore only be evaluated for correct operation when installed.



Testing must be completed by specialist personnel or can be contracted out to TROX X-FANS.

Speed control, special provisions

By changing the speed, additional acceleration forces are applied to the fan components:

- Changes to the speed during controlled operation must not cause the permissible motor temperatures and bearing loads to be exceeded.
- The run-up time should therefore be approx. 60 seconds.
- Changes to the speed to adjust process variables (controlled operation) should be max. 16.7 rev/sec (1.75 rad/sec), except when running through resonance frequencies.
- The fans' service life can be increased by quickly running through resonance frequencies.
- The operating manuals from the control unit manufacturer must be observed.
- The EMC Directive 2014/30/EU must be complied with.

General notes

- The motor and transformer must be positioned as close to one another as possible
- Cables must be sheathed and shielded
- Cables, cable ends, the frequency inverter and the motor must be earthed.
- It is advisable to use all-pole sine filters.

3.6.3 Smoke extract

During smoke extract operation, the fans only extract smoke gases in the event of a fire to remove the smoke from the fire compartments.

Rating plate

CE marking of smoke exhaust fans (BV)

		0761 - MPA Braunschweig		TROX TLT GmbH Heinz-Trox-Straße 1 GER 36251 Bad Hersfeld +49 (0)5621950-0 www.trox-ll.de	
EN 12101-3: 2015		BVAXN 12/56 F400			
DoP BVAXN 12/56 F400			14		
intended to be installed as a part of a powered smoke and heat control ventilation system					
response delay					
- opening under wind load within a given time:		NPD			
- opening under snow load within a given time:		NPD			
operational reliability					
- application category:		dual purpose			
- motor rating:		H, 100 K			
effectiveness of smoke / hot gas extraction					
- gas flow and pressure maintenance during smoke and heat extraction test:		± 10 % / ± 20 %			
resistance to fire					
		F ₂₀₀ F ₃₀₀ F ₄₀₀			
ability to open under environmental conditions					
- opening under wind load within a given time:		NPD			
- opening under snow load within a given time:		NPD			
durability of operational reliability		H, 100 K			

Fig. 12: CE marking

The rating plate of the smoke exhaust fans (BV) also contains information about the application and permissible temperature / time category.

In addition, a CE mark as per EN 12103, Part 3, is attached to demonstrate product conformity.

3.7 Rating plate

		TROX TLT GmbH Heinz-Trox-Straße 1 D-36251 Bad Hersfeld +49 (0)5621950-0 E-Mail: info@trox-ll.de Made in Germany	
job number:	123456789	12345678901234567890	year
item number:	123456789012345678901234		01/17
type designation:	123456789012345678901234567890		
q _v	100.000 / 75.000 / 50.000	m ³ /h	Θ -25 - 60 °C
p _r	1.500 / 1.250 / 1.000	Pa	Θ _s 50 °C
p _{st}	1.500 / 1.250 / 1.000	Pa	ρ 1,2 kg/m ³
P _r	55,0 / 32,0 / 15,0	kW	m 500 kg
N	3.000 / 1.500 / 1.000	rpm	N _{max} 3.000 rpm
η _e / η _s	0,75 / 0,66	SFP	1234 Ws/m ³
installation category (ISO 5801)	B	F	75 / 10 N
η _e / η _s (opt.)	0,80 / 0,70	F _{av}	45 / 5 N
η _e / η _s (ERP2015)	0,80 / 0,70	VME	0,52 / 0,25 - / m ³
	2014/35/EU, 2014/30/EU, 2006/42/EC, 2011/65/EC		
	ATEX 2014/34/EU II 2/2 G cb IIB+H2 T4		
	operation only with frequency converter		
Note			

Fig. 13: Fan's rating plate

- Manufacturer
- Year of manufacture
- Manufacturing no.
- Part no.

- Type
- Volume flow rate
- Speed
- Motor rating
- Total pressure increase
- Voltage (V) / frequency (Hz)

The rating plate of the explosion-proof fan also includes the following information:

- Explosion protection mark
- Category

		3~					
		N°					
IP 55 IK08 cl.		40°C S S1				kg	
		V	Hz	min ⁻¹	kW	cosφ	A
人 人		400	50	2865	1,80	0,82	4,30
人		400	50	1450	0,37	0,76	0,90
300°C-120min CTICM n°03-H-349							
THERMOCK (ROSSEL)							
EN 12101-3 Dual Purpose IC418 IdHC-TdB							

Fig. 14: Electric motor's rating plate

4 Parts and function

4.1 Overview

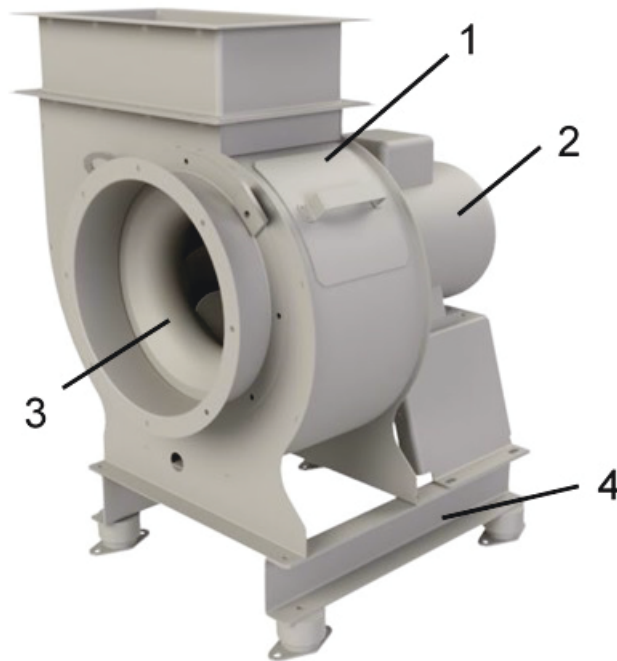

Fig. 15: Structure of centrifugal fan

- | | | | |
|---|----------------|---|------------|
| 1 | Casing | 3 | Impeller |
| 2 | Electric motor | 4 | Base frame |

4.2 Description of the sub-assembly

4.2.1 Casing

Fan casing in spiral form as welded construction with sturdy reinforcement frame and bolted-on foot frame parts, surface protection by single-component synthetic paint colour RAL 7030 (stone grey)

4.2.2 Impeller



Fig. 16: Impeller

– Impeller made of sheet steel in welded construction with backward curved blades, surface protection by polyester powder coating, colour RAL 7030 (stone grey)

4.2.3 Belt drive

The fan shaft is driven by a narrow V-belt drive. The belt pulleys must be precisely aligned, and the belt tension must comply with requirements. The grooves of the V-belts must be free from rust, grease and dirt and must not be damaged. Contamination by oils, greases or chemicals must be avoided.

4.2.4 Fixing

The fans are to be fixed to a flat surface (base frame, etc.) free from tension and torsion.

4.2.5 Actuator

Electric motor

Centrifugal fans are equipped with electric motors from different manufacturers and of different sizes. The motor characteristics are provided in the enclosed documentation and the rating plate for the electric motor (↪ 3.7 'Rating plate' on page 20).

In the case of the explosion-proof construction, the fan is equipped with an explosion-proof electric motor.

Terminal box (standard)



Fig. 17: Terminal box

The terminal box including the electric connections is mounted to a bracket on the fan.

An ATEX construction of the terminal box is used for explosion-proof fans.

Isolator



Fig. 18: Isolator

The isolator is mounted to a bracket on the fan. If the switch is supplied separately, it must be installed by a qualified electrician.

4.2.6 Additional equipment for centrifugal fans

VD fan diagnostic system (or shock pulse measurement)



Fig. 19: VD-R2-1_6

The VD fan diagnostic system monitors the state of the fan by measuring physical characteristics. This facilitates maintenance of the fans. The replacement intervals for components and motors are extended.

Volume flow rate measuring unit VME

The volume flow rate measuring unit (VME) determines the operating volume flow rate and enables quick and affordable fan regulation.

The measuring point of the ring measuring line of the intake-side VME shaft must be connected to the VME connecting braked on the fan with a measuring hose. In general, the measuring hose for the VME shaft is pre-laid to the fan. The open end is attached to the fan as a ring for transport purposes. During the installation of the VME, this measuring hose is connected to the ring measuring cable of the VME shaft. **For more information, see the separate instructions.**

5 Transport, packaging and storage

5.1 Safety notes regarding transport

Suspended loads

DANGER!

Danger of death due to suspended loads!

Falling loads may cause serious injury or death.

Therefore:

- Never walk under suspended loads.
- Only move loads under supervision.
- Observe the specifications for the intended lashing points.
- Do not attach the lifting gear to protruding machine parts or lugs on attached components
- Ensure that the lifting gear is secure.
- Only use approved hoisting devices and lifting gear with sufficient load-bearing capacity.
- Do not use any frayed or worn ropes and belts.
- Do not place ropes or belts near sharp edges or corners; do not knot or twist.
- Place the load on the ground before leaving the workplace.

Improper transport equipment

NOTICE!

Damage due to improper transport!

A significant amount of property damage can be caused by improper transport.

Therefore:

- Be careful when unloading the packages upon delivery and during internal transport, and pay attention to the symbols and information on the packaging.
- Only use the intended lashing points.
- Do not remove the packaging until immediately before assembly.

NOTICE!

During transport, shock loads must be avoided at all costs. If shocks cannot be avoided, the fan bearing must be relieved first. The fan must be secured against slipping and tipping.

To prevent damage caused by violent impacts and careless loading and unloading, the transport must be carried out with the necessary care and caution.

During installation, the fan must not be set down too hard as this can lead to deformation of the casing and bearing damage.

5.2 Checking delivered goods

Check the delivery for transport damage and to ensure that it is complete as soon as it arrives.

Transport damage

If there is any visible damage, proceed as follows:

- Either do not accept the delivered items, or accept them with reservations.
- Note down the damage on the shipping documents or on the shipping company's delivery note.
- File a complaint.



File a complaint as soon as you detect any damage. Claims for damages can only be filed within the applicable complaint periods.



EXPLOSION HAZARD!

Goods damaged while in transit are unsuitable for use in potentially explosive atmospheres.

Therefore:

- *Do not commission the unit if any transport damage is visible. Contact the manufacturer.*

Failure to comply with this note leads to loss of the explosion protection!

5.3 Packaging

Information on packaging

The individual packages are packed in accordance with the expected transport conditions. Only environmentally-friendly materials have been used for the packaging.

The packaging should protect the individual components from transport damage, corrosion and other damage until they are assembled. Therefore, do not destroy the packaging and only remove it immediately before assembly.

5.4 Symbols on the packaging

Handling packaging materials

Properly dispose of packaging material.



ENVIRONMENT!

Environmental damage due to improper disposal!

Packaging materials are valuable raw materials and can, in many cases, be reused or properly reconditioned and recycled.

Therefore:

- Dispose of packaging materials in an environmentally sound manner.
- Observe the applicable local disposal regulations. If necessary, employ a specialist disposal company to dispose of the packaging.

5.5 Factory settings

The fan is delivered as a fully assembled unit.

The packaging selected is suitable for transport to the intended destination. Fans are delivered packed on pallets or unpacked.

A control chart is provided with every fan. It is used to document the performance data measured on the manufacturer's premises. On delivery, the control chart is sealed in waterproof packaging to the outside of the fan.

Required accessories, replacement parts and the operating manual are packed separately and enclosed.

5.6 Transport

Lashing points

Depending on the size of the fan, it can be fitted with lifting eyes.

Transporting packages with a crane

The fan can then be transported directly with a crane, under the following conditions:

The crane and hoisting devices must be designed for the weight of the fan.

The operator must be authorised to operate the crane.

Lashing:

1. ▶ Lash ropes, belts or multiple-point suspension gear to the lifting eyes.

2. ▶ Ensure that the package is hanging straight and observe the offset centre of gravity if necessary.
3. ▶ Start transport.

The fan can be transported directly with a crane as detailed in points 1 to 3.

Transporting pallets with a forklift



Fig. 20: Carrying load with a forklift

Fans that are attached to pallets can be transported with a forklift under the following conditions:

- The forklift must be designed for the weight of the transport unit.
- The driver must be authorised to drive the forklift.

Lashing:

1. ▶ Drive the forklift with the forks between or under the struts of the pallet (Fig. 20).
2. ▶ Push the forks through until they protrude on the opposite side.
3. ▶ Ensure that the load cannot tip.
4. ▶ Lift the package and start transport.

Transporting pallets with a crane

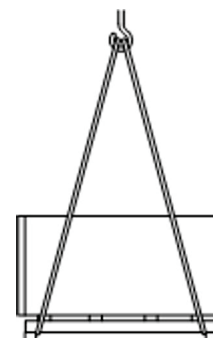

Fig. 21: Transport with a crane

Packages that are attached to pallets can be transported with a crane, under the following conditions:

Storing packages

The crane and hoisting devices must be designed for the weight of the packages.

The operator must be authorised to operate the crane.

Lashing:

1. ▶ Lash ropes, belts or multiple-point suspension gear to the pallet in accordance with (Fig. 21).
2. ▶ Check to ensure that the packages are not being damaged by the lifting gear. Use different lifting gear if necessary.
3. ▶ Start transport.

5.7 Storing packages

- If you have to store packages temporarily:
- Store in a dry and dust free place.
- Do not expose to any aggressive gases or liquids.
- Avoid mechanical shocks.
- Manually turn the impeller by 5 whole revolutions once a month.
- If a unit has to be stored for more than 3 months, regularly check the general condition of all parts and of the packaging. Refresh corrosion protection, if necessary.



Note!

Packages may contain additional important information on storage requirements. These must be observed accordingly.

6 Installation and commissioning



IMPORTANT!

Assembly / installation and commissioning is either completed by the manufacturer or instructed personnel.



WARNING!

Danger due to improper assembly / installation and commissioning!

Errors during assembly / installation can lead to potentially fatal situations or cause considerable property damage.

Therefore:

- Only allow the manufacturer's employees or authorised personnel to carry out assembly / installation and commissioning.

6.1 Safety

Personnel

- Assembly / installation and commissioning must only be carried out by instructed personnel or by the manufacturer.
- Work on the electrical system must only be carried out by qualified electricians.

Personal protective equipment

Wear the following protective equipment during all installation and initial commissioning work:

Protective equipment:

- Protective clothing
- Safety helmet
- Safety shoes
- Protective gloves

Electrical system



DANGER!

Danger of death due to electric current!

Danger of electric shock! Do not touch any live components! Damaged insulation or damaged parts are a life threatening hazard.

- Have work on the electrical system carried out only by skilled qualified electricians.
- If the insulation is damaged, disconnect the power supply immediately and have the insulation repaired.
- Before you start working on electric systems and equipment, switch off the supply voltage and secure it against being switched on accidentally. Comply with the 5 safety rules:
 - Disconnect.
 - Secure it against being switched on accidentally.
 - Ensure that no voltage is present.
 - Connect to the earth; short circuit connection.
 - Either cover nearby parts that carry a voltage or install barriers.
- Do not bypass or disable any circuit breakers. Be sure to maintain the correct current rating when you replace a circuit breaker.
- Ensure that live parts do not come into contact with moisture. Moisture can cause a short circuit.

Explosion protection

EXPLOSION HAZARD!

Ignition sources, such as sparks, naked flames and hot surfaces, can lead to explosions in potentially explosive atmospheres. The following therefore applies to all work on units in the Ex area:

- Get written permission before you start the work.
- Only perform work if there are no dust deposits or a potentially explosive atmosphere.
- Use only tools that have been approved for use in areas with potentially explosive atmospheres.

Additionally:

- It must be ensured that sufficient cooling air is supplied to the fan drive motor at all times.
- Motors with a cover must be used if fans with a vertical motor shaft are installed.
- Servicing and maintenance work on explosion-proof fans must only be carried out by qualified personnel with the relevant explosion protection qualifications using original replacement parts

Failure to comply with these notes leads to loss of explosion protection and may result in serious injury and death.

Smoke extract

NOTICE!

During installation, the relevant standards and guidelines (EN 12101-3, VDMA 24177, DIN 18232-5) must be adhered to with regard to installation requirements and distances from combustible building materials.

Smoke extract takes precedence over all other functions of the fan!

In smoke extract situations, you should therefore use suitable switchgear for the following purposes:

- Switching on the fan
- Shunting/switching off all thermal and electrical monitoring elements
- Switching the fan to projected speeds

Make sure that the fan stays on after an automatic activation!

Frequency inverters (FI) must only be used in one of the combinations of smoke exhaust fan and FI certified in accordance with EN 12101-3! For more information, see the TROX X-FANS product range.

It is not permissible to control the fan speed in the event of a fire!

6.2 Installation

6.2.1 Assembly of the fan



For maintenance and repair work, ensure accessibility to the fan and sufficient clearance!

Personnel:

- Instructed person
- Skilled qualified electrician

Preparations

Before starting assembly work, check:

- Compliance of the local energy supply with the information provided on the rating plate and the specifications provided in the technical data.
- All of the required documents are available.
- Completeness and perfect condition of the required tools and auxiliary materials.
- Compliance with the local safety regulations.

Assembly of centrifugal fans

1. ▶ The fan must be fixed to a flat surface (floor, steel construction, etc.) free from tension and torsion.



IMPORTANT!

A vibration-damped installation is recommended. Rubber or spring vibration dampers, as well as flexible connectors, (compensators) can be used here.

After assembly, make sure the impeller is running without grinding.

2. ▶ Fix the fan to the duct system.



IMPORTANT!

Use threadlocker

3. ▶ Insert cables into the terminal box and seal. Check the terminal box on the motor or fan for the required and suitable connection mode (bridge holding) for on-site connection and change, if necessary.



Fig. 22: Example of terminal diagram

4. ▶ Observe the specifications provided on the rating plate.
5. ▶ Compare the supply voltage.
6. ▶ Carefully close off any unused cable inserts in the terminal box to protect against dust and moisture.
7. ▶ Tighten all of the contact screws and nuts to prevent excessive contact resistances. Fit wire clamping brackets to the cable glands for the on-site cable. If installed outdoors, ensure that the inserts for the supply cables in the terminal box attached to the casing are watertight.
8. ▶ Complete any electrical connections in accordance with the terminal diagram provided in the terminal box.
9. ▶ Connect PTC thermistors/thermal contacts (optional) for motor protection.



Fig. 23: Arrow indicating direction of rotation

10. ▶ Check the direction of rotation of the electric motor.
- Briefly (< 1 s) supply the fan with supply voltage.
 - Compare the direction of rotation of the electric motor with the running direction arrows on the fan.
Reverse the polarity if necessary.

The energy supply, as well as the release and control of smoke exhaust fans, must correspond to the building regulations.

6.2.2 Additional smoke extract work

! NOTICE!

Smoke extract

Smoke exhaust fans **BVREH** and **BVRA** are suitable for installation outside the fire zone according to the tested temperature/time category. **BVREH** can also be installed outdoors.

Spring vibration dampers and temperature-resistant compensators must be used.

In case of installation installing in rooms outside the fire zone, the smoke exhaust fan must be provided with thermal insulation. This also applies to all connecting parts like pipes, ducts, etc.

The ambient temperature of the smoke exhaust fan must never exceed 40°C.

For safe operation in the event of a fire, the following should be observed:

- **In the event of a fire, the feed and control input signal must be clarified with the responsible approval/fire protection authorities and the system owner.**
- Outside of fire rooms, the supply line should be laid protected by an armoured pipe and spacers or in a heat-protected E90 construction.
- For outdoor installation, the supply cable must be inserted into the terminal box located on the motor from below or from the side in a watertight manner.
- When the insulated fan is installed outside of the fire zone or outdoors, there are no requirements regarding the temperature resistance of the cable. In any case, however, non-temperature-resistant supply lines must not be fixed to or leaned on the fan casing.
- The switch cabinet should be placed outside the fire hazard areas. It should not be attached to walls belonging to the fire compartment.
- Thermal contacts or PTC thermistors must be shunted for the fire circuit. **In the event of a fire, the motor must not be switched off by any motor protection device.**

6.2.3 Assembly of the flexible connector

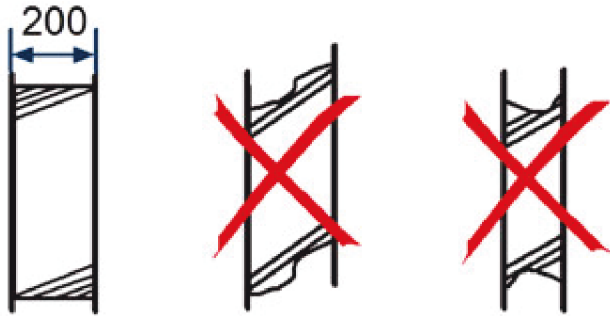

Fig. 24: Installation details; installation dimensions for the F600 construction: 90 mm

IMPORTANT!

- Flexible connectors must be installed according to the installation length without any offset. Incorrect installation results in reduced output and increases the amount of noise.
- Flexible connectors are not designed to compensate for assembly-related inaccuracies.
- When securing with loose flanges, ensure that the separating points of the flange are offset by approx. 180°.
- Only remove the protective and spacing packaging after assembly (for connector up to 400°C).

6.2.4 Assembly of V-pulleys for anti-vibration elements

When installing the fan on vibration isolators, care must be taken to ensure the correct fit of the V-pulleys. These are used to compensate for the slant of the base frame profile.

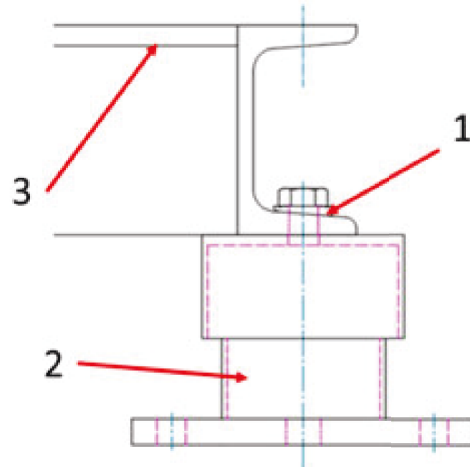

Fig. 25: V-pulley assembly

- 1 V-pulleys
- 2 Isolator
- 3 Base frame profile

6.3 Commissioning

6.3.1 System with inductor/return smoke control dampers

Dampers that can completely stop the airflow must be connected in such a way that the fan is switched off immediately after they are closed. Otherwise, impermissible heating of the fan and impermissible vibrations caused by flow separation can occur.

6.3.2 Reversing the direction of rotation

A sudden change in the direction of rotation due to switching over the power supply, for example, can damage the impeller and must therefore be avoided and/or is impermissible under all circumstances. The fan should be started when the impeller is at a standstill.

6.3.3 Explosion-proof fans

Special care and attention is absolutely essential. In addition to all of the guidelines, it must be ensured that build-up of electrostatic charges is prevented by earthing the components if necessary. Special care must be taken to ensure that the safety distances between rotating and fixed parts are observed and that the drive motors are not overloaded under any circumstances.

EXPLOSION HAZARD!

Ignition sources, such as sparks, naked flames and hot surfaces, can lead to explosions in potentially explosive atmospheres. The following therefore applies to all work on units in the Ex area:

- Get written permission before you start the work.
- Only perform work if there are no dust deposits or a potentially explosive atmosphere.
- Use only tools that have been approved for use in areas with potentially explosive atmospheres.

Additionally:

- It must be ensured that sufficient cooling air is supplied to the fan drive motor at all times.
- Motors with a cover must be used if fans with a vertical motor shaft are installed.
- Servicing and maintenance work on explosion-proof fans must only be carried out by qualified personnel with the relevant explosion protection qualifications using original replacement parts

Failure to comply with these notes leads to loss of explosion protection and may result in serious injury and death.

- The intake-side and discharge-side connection parts, as well as the duct system, must be fully assembled.
- After the electrical connection of the fan motor has been established, you must check whether the direction of rotation of the motor is correct by briefly switching the motor on and off. The direction of rotation must match the direction of rotation arrow on the fan. It may vary depending on the construction style.
In case of an incorrect direction of rotation, a live wire exchange must be performed.
- Under no circumstances must the impeller grind on the casing.
- The current consumption of the motor shall be measured and compared with the maximum nominal current indicated on the rating plate.
- The first test run should be at least 6 hours. The purpose of this test run is that the bearing is warmed up, the grease is distributed correctly and running noises are reduced.
- Since vibrations can occur in the fan for system-related reasons after installation, care must be taken to ensure low-vibration operation during commissioning.
This is especially true for fans with several speeds or speed control, where entire speed ranges must be checked using vibration measurements.
- The fan must not be operated in chopping conditions (poor flow or system resistance higher than calculated). It must run at its intended operating point. Measure the airflow and pressure increase and compare them with the information on the rating plate.

6.3.4 Correct initial commissioning

Correct initial commissioning

IMPORTANT!

Observe the commissioning report (☞ 'Commissioning report' on page 47) and maintenance report (☞ 'Maintenance report' on page 49) in the appendix!

- Before commissioning the smoke extraction fan, it must be cleared of foreign matter (tools, dirt, water, etc.).
- All screw connections must be checked for a firm seat.
- The cover grille required for free suction and or blow-out must be installed.
The V-belt protection must be installed.
The fan must not be operated without the necessary protective devices!

7 Operation

7.1 Safety

⚠ WARNING!

Risk of injury from incorrect operation!

Incorrect operation can result in serious injury or property damage.

Therefore:

- Complete all of the operating steps according to the information provided in this operating manual.
- Before starting, ensure that all of the covers and safeguards have been installed and are working properly.
- Never deactivate safeguards during operation.
- Any existing inspection flaps must only be opened when the fan is at a standstill.

Operation as an individual unit

1. ▶ Ensure that there is no foreign matter located within or in the direct vicinity of the unit.



Fig. 26: Isolator

2. ▶ Switch the fan with isolator on and off (Fig. 26).

Operation in a plant system

When the fan is installed in a plant system, it is operated via the plant system rather than on the unit.

7.2 Stopping in an emergency

In hazardous situations, the machine movements must be stopped as quickly as possible and the energy supply must be disconnected.

Stopping in an emergency

Proceed as follows in a hazardous situation:

1. ▶ Immediately initiate an emergency stop.
2. ▶ Inform the responsible person at the operation site.
3. ▶ Alert a doctor and the fire service.
4. ▶ Rescue individuals from the hazardous area and perform first aid.
5. ▶ Switch off the mains isolator and secure it against being switched back on again.
6. ▶ Keep access paths for rescue vehicles clear.

After the rescue measures have been implemented

7. ▶ Inform the responsible authorities if required by the severity of the emergency.
8. ▶ Task specialist personnel with troubleshooting.

⚠ WARNING!

Danger of death due to early reactivation!

During reactivation, there is a danger of death for all persons in the hazardous area.

Therefore:

- Before reactivation, ensure that persons are no longer in the hazardous area.

9. ▶ Before recommissioning the plant, check and ensure that all of the safeguards are installed and fully functional.

8 Faults

WARNING!

Risk of injury due to improper installation, initial commissioning and troubleshooting!

Improper installation and initial commissioning can result in serious personal injury or property damage.

Therefore:

- Before you start, make sure that there is sufficient clearance for the work you have to complete.
- Handle open, sharp-edged components with care.
- Keep the work area tidy and clean. Parts and tools that are loosely stacked or left lying around are a source of accident.
- Assemble components properly. Comply with the specified screw tightening torques (see  'Tables' on page 52 in the appendix).
- Secure components so that they do not fall down or topple over.

The following chapter describes possible causes of faults and the work required to eliminate them. If faults occur more frequently, reduce the maintenance intervals in accordance with the actual load. Contact the manufacturer if any of the faults cannot be eliminated using the following information; see the service address on page 2.

8.1 Safety

Personnel

- Unless specified otherwise, the troubleshooting work described here must be carried out by the operator (user).
- This is specified separately in the description of the individual faults.
- Work on the electrical system must only be carried out by qualified electricians as a matter of principle.
- Repair work (particularly welding) on the impeller and on load-bearing and connecting structures must only be carried out by the manufacturer.
- The impeller must only be rebalanced by the manufacturer or a specialist company.

EXPLOSION HAZARD!

Use only tools that have been approved for use in areas with potentially explosive atmospheres.

Electrical system

DANGER!

Danger of death due to electric current!

Danger of electric shock! Do not touch any live components! Live electrical components may execute uncontrolled movements and cause serious injury.

Therefore:

- Before starting work, switch off the electrical supply and secure it against being switched back on again.

Securing the unit against being switched on accidentally

DANGER!

Danger of death due to unauthorised reactivation!

During troubleshooting work, there is a risk of the power supply being switched back on without authorisation. There is therefore a danger of death for the persons in the hazardous area.

Therefore:

- Before starting work, switch off all of the power supplies and secure them against being switched back on again.

Explosion protection

EXPLOSION HAZARD!

Ignition sources, such as sparks, naked flames and hot surfaces, can lead to explosions in potentially explosive atmospheres. The following therefore applies to all work on units in the Ex area:

- Get written permission before you start the work.
- Only perform work if there are no dust deposits or a potentially explosive atmosphere.
- Use only tools that have been approved for use in areas with potentially explosive atmospheres.

Additionally:

- It must be ensured that sufficient cooling air is supplied to the fan drive motor at all times.
- Motors with a cover must be used if fans with a vertical motor shaft are installed.
- Servicing and maintenance work on explosion-proof fans must only be carried out by qualified personnel with the relevant explosion protection qualifications using original replacement parts

Failure to comply with these notes leads to loss of explosion protection and may result in serious injury and death.

2. ▶ Determine the cause of the fault.
3. ▶ If troubleshooting requires work to be performed in the hazardous area, switch off the system and secure it against being switched back on again.
4. ▶ Immediately inform the responsible person at the operation site of the fault.
5. ▶ Depending on the type of fault, ensure that it is eliminated by authorised specialist personnel or rectify it yourself.

IMPORTANT!

The fault table below sets out who is authorised to rectify which fault.

WARNING!

Risk of injury due to improper installation, initial commissioning and troubleshooting!

Improper installation and initial commissioning can result in serious personal injury or property damage.

Therefore:

- Before you start, make sure that there is sufficient clearance for the work you have to complete.
- Handle open, sharp-edged components with care.
- Keep the work area tidy and clean. Parts and tools that are loosely stacked or left lying around are a source of accident.
- Assemble components properly. Comply with the specified screw tightening torques (see  'Tables' on page 52 in the appendix).
- Secure components so that they do not fall down or topple over.

Behaviour in the event of faults

Please note:

1. ▶ If faults that pose an immediate danger to persons or property occur, immediately trigger the emergency stop function.

8.2 List of faults

Fault description	Cause	Remedy	Personnel
Fan does not start	Motor connected incorrectly	Check the connections	Skilled qualified electrician
	No power	Check the power supply	Skilled qualified electrician
	One or two live wires have failed	Check the power consumption	Skilled qualified electrician
	Belt not assembled correctly	Ensure that the belt is positioned correctly	Instructed person
Electric motor switches off	Electric motor is too warm, thermal contact triggers	Allow the electric motor to cool down. Depending on the control module, the fan either automatically starts up again or it has to be restarted.	Skilled qualified electrician
		<i>Impeller sluggish? Bearing damaged?</i> Replace the impeller or motor bearing if necessary	Instructed person
	Electrical connection is faulty	<i>Are all of the live wires loaded equally and connected?</i> Check the power consumption / direction of rotation	Skilled qualified electrician
	Motor is overloaded	<i>Does the operating point match the sizing?</i> Replace the motor with a more efficient one	Skilled qualified electrician
Fan does not reach the nominal speed	Motor starting torque is too low for ramping up	Replace the motor or provide a start-up system	Skilled qualified electrician
Air volume flow rate is incorrect	Direction of rotation of fan is incorrect	<i>A centrifugal fan always blows air out, even if it is rotating in the incorrect direction</i> Change the direction of rotation by switching two live wires on the terminals	Skilled qualified electrician
	Impeller no longer suitable because the casing has been changed	<i>The blades are then curved in the incorrect direction as there are different impellers for clockwise and anticlockwise rotation.</i> Installation of an impeller that is suitable for the type of casing	Instructed person
	Impeller blocked	Switch off the fan and remove the blockage. Observe the accident prevention regulations.	Instructed person
	Impeller defective	Switch off the fan. Dismantle the impeller and replace it with a new one.	Instructed person
	The impeller speed is incorrect	<i>Motor speed incorrect?</i> Check the motor or belt drive, replace if necessary	Instructed person
		<i>Ratio of the belt pulley diameter is incorrect?</i> Replace the belt drive	Instructed person
		<i>V-belt slip is too high?</i> Tension the V-belt	Instructed person
		<i>Frequency inverter parameterised incorrectly?</i>	Skilled qualified electrician

List of faults

Fault description	Cause	Remedy	Personnel
Air volume flow rate is incorrect		Change the frequency inverter parameter settings	
	The duct system pressure losses are higher than expected / calculated	<i>At which operating point is the fan running?</i> Change the duct version; prevent turbulence using baffle plates. Increase the fan speed (note: do not exceed the motor limit rating or the maximum fan speed)	Instructed person
		<i>Is the operating point in the unstable range?</i> Resize and replace the fan Open the bypass Reduce pressure losses in the duct	Instructed person
	Dampers or grilles in the system are closed	Open the dampers or grilles	Instructed person
	An object is obstructing the airflow in the duct	Clean the duct / remove the obstruction	Instructed person
	Vane controls are (partially) closed	Open the vane control	Instructed person
	Filter is dirty	Clean or replace the filter	Instructed person
Fan is pumping	Fan is working in an unfavourable characteristic curve range	Reduce the system resistances.	Instructed person
Increased vibrations	Impeller imbalance due to deposits	<i>Please note that the system, consisting of the impeller, crankshaft, belt pulleys and belt, always has a residual imbalance, even if all of the components are balanced!</i> Clean and rebalance the impeller	Instructed person
	Belt pulleys have an inadmissible unbalance	Rebalance the system	Instructed person
	Belt knocking too much	Retention the belt	Instructed person
	Vibration isolators are assembled or positioned incorrectly	<i>Incorrectly selected vibration isolators can result in the destruction of the fan!</i> Construct and assemble vibration isolators correctly	Instructed person
	Vibration isolators are the wrong size	Replace the vibration isolators	Instructed person
Air noises	Direction of rotation is incorrect	Change the direction of rotation by switching two live wires on the terminals	Skilled qualified electrician
	Pulsating volume flow rate	Increase the cross sections to improve the passage of air Install baffle plates	Instructed person
		<i>Is the operating point in an unstable range?</i> Implement measures to reduce the overall pressure loss	Instructed person
Mechanical noises	Belt drive not tensioned sufficiently	<i>V-belts must be retensioned after a warm-up time</i> Tension the V-belt	Instructed person

Commissioning once a fault has been rectified

Fault description	Cause	Remedy	Personnel
Mechanical noises	Belt protection not attached correctly	Fix the belt protection	Instructed person
	Contamination on the casing or impeller	Clean the casing / impeller	Instructed person
	Impeller is grinding	<i>Caused by a misaligned connection duct due to deformation of the casing, for example.</i> Check the impeller gap Realign the fan Readjust the impeller Correct V-belt pre-tension	Instructed person
	Bearing noises	<i>Some bearings make clicking noises that can be disregarded!</i> Check the bearings and replace them if necessary	Instructed person
	Bearing running dry	Regrease bearing according to table	Instructed person
Bearing temperature too high	Not enough grease or greased is used up	Regrease bearing according to table	Instructed person
	Bearing defective	Replace bearing	Instructed person
	V-belt pre-tension too high	Correct V-belt pre-tension	Instructed person

8.3 Commissioning once a fault has been rectified

Once the fault has been rectified, work through the following steps for recommissioning:

1. ▶ Reset the emergency stop equipment.
2. ▶ Acknowledge the fault on the control.
3. ▶ Ensure that nobody is in the hazardous area.
4. ▶ Start in accordance with the information in the chapter entitled “ 7 ‘Operation’ on page 32”.

9 Maintenance

Maintenance can be completely subdivided into the following basic measures: servicing, inspection, maintenance and improvement. It includes:

- Consideration of internal and external requirements
- Coordination of the maintenance targets with the corporate objectives
- Adherence to the relevant maintenance strategies

9.1 Personnel requirements

Qualifications

 **WARNING!**

Danger of injury due to insufficiently qualified individuals!

Incorrect use may cause considerable injury or damage to property.

Therefore:

- Only specialist personnel must carry out work.

The following degrees of qualification are required for the work described in the operating manual:

Personnel:

- Instructed person
- Specialist personnel
- Skilled qualified electrician

Only persons who can be expected to perform their work reliably are acceptable as personnel. Individuals whose reaction time is delayed due to alcohol, drugs or other medication must not carry out any work.

- The age-specific and occupational regulations applicable at the operation site must be observed when appointing personnel.

9.2 Safety

Personnel

- The maintenance work must only be carried out by instructed persons or by the manufacturer.
- Work on the electrical system must only be carried out by qualified electricians as a matter of principle.

Personal protective equipment

Wear the following protective equipment during all maintenance work:

Protective equipment:

- Safety helmet
- Hearing protection
- Protective gloves

- Safety shoes
- Protective clothing

 **IMPORTANT!**

Other protective equipment that has to be worn for certain work is indicated separately in the warnings included in this chapter.

Electrical system

 **DANGER!**

Danger of death due to electric current!

Danger of electric shock! Do not touch any live components! Damaged insulation or damaged parts are a life threatening hazard.

- Have work on the electrical system carried out only by skilled qualified electricians.
- If the insulation is damaged, disconnect the power supply immediately and have the insulation repaired.
- Before you start working on electric systems and equipment, switch off the supply voltage and secure it against being switched on accidentally. Comply with the 5 safety rules:
 - Disconnect.
 - Secure it against being switched on accidentally.
 - Ensure that no voltage is present.
 - Connect to the earth; short circuit connection.
 - Either cover nearby parts that carry a voltage or install barriers.
- Do not bypass or disable any circuit breakers. Be sure to maintain the correct current rating when you replace a circuit breaker.
- Ensure that live parts do not come into contact with moisture. Moisture can cause a short circuit.

Securing the unit against being switched on accidentally

DANGER!

Danger of death due to impermissible activation and deactivation!

During maintenance work, there is a risk of the power supply being switched back on without authorisation. There is therefore a danger of death for the persons in the hazardous area.

Therefore:

- Before starting work, switch off all of the power supplies and secure them against being switched back on again.

Explosion protection

EXPLOSION HAZARD!

Ignition sources, such as sparks, naked flames and hot surfaces, can lead to explosions in potentially explosive atmospheres. The following therefore applies to all work on units in the Ex area:

- *Get written permission before you start the work.*
- *Only perform work if there are no dust deposits or a potentially explosive atmosphere.*
- *Use only tools that have been approved for use in areas with potentially explosive atmospheres.*

Additionally:

- *It must be ensured that sufficient cooling air is supplied to the fan drive motor at all times.*
- *Motors with a cover must be used if fans with a vertical motor shaft are installed.*
- *Servicing and maintenance work on explosion-proof fans must only be carried out by qualified personnel with the relevant explosion protection qualifications using original replacement parts*

Failure to comply with these notes leads to loss of explosion protection and may result in serious injury and death.

WARNING!

Risk of injury from incorrect maintenance!

Incorrect maintenance can result in serious injury or property damage.

Therefore:

- Maintenance work must only be carried out by qualified personnel who have been authorised by the system owner.
- Before you start, make sure that there is sufficient clearance for the work you have to complete.
- If components have been replaced, ensure that they are assembled correctly, reinstall all of the fixing elements, and tighten all screws with the correct tightening torque (see  'Tables' on page 52 in the appendix).
- Before reactivation, ensure that all of the covers and protective devices are installed correctly and are working properly.

WARNING!

Risk of injury from rotating parts!

Rotating parts in the fan can cause serious injuries.

Therefore, before performing any maintenance work:

- Bring the fan to a proper standstill and disconnect it from the power supply.
- Never reach into the running fan.
- Wait for the impeller to come to a standstill.
- Do not stop the impeller manually.
- Secure the fan against being switched back on again.

ENVIRONMENT!

Observe the following notes on environmental protection during maintenance work:

- At all lubricating points that are supplied with lubricant manually, remove the escaping, used or excess grease and dispose of it in line with the applicable local regulations.

9.3 Maintenance

The following sections describe the maintenance jobs required to ensure efficient and fault-free operation.

If increased wear is detected on individual components or functional groups during regular checks, the required maintenance intervals must be reduced based on the actual signs of wear. The intervals are dependent on the conveyed media and the other operating conditions that differ in each case.

If the check indicates even a slight amount of wear, clean the individual parts in good time and replace if necessary.

The impeller and casing suffer from natural wear due to the carried dust, acidic and corrosive vapours and gases that are added to the flow rate. The type and concentration of the dust, gases and vapours result in deposits, erosion and corrosion on the impeller and casing.

This natural wear can damage the material in such a way that it no longer withstands the loads.

Deposits on the impeller that are never distributed evenly have an imbalance and thus cause irregular running which damages the motor bearing.

Deposits in the casing narrow the free cross section or roughen the inside of the casing and thus have an adverse effect on the fan's performance data.

A component's surface protection must be checked on a regular basis and maintained if necessary. Note that stones, dust abrasion or chemical loads, for example, can cause mechanical damage to the surface. Even stainless steel can be affected by surface corrosion, for example if salts or aggressive gases are present in a very moist atmosphere.

It should be noted in this regard that surface corrosion generally does not impair the fan's characteristics and cannot, therefore, be classed as a warranty claim. Instead, it must be repaired or eliminated by taking suitable maintenance measures even during the warranty period. Typically, the corrosion can be stopped by cleaning the surface and implementing suitable surface preservation.

If you have any questions about the maintenance work and intervals, contact the manufacturer (service address on page 2).

IMPORTANT!

Document commissioning and maintenance (functional check) with the relevant report templates ('Commissioning report' on page 47) and maintenance report ('Maintenance report' on page 49 in appendix).

9.3.1 Use of monitoring systems

The use of monitoring systems simplifies the required maintenance work and checks.

Maintenance of the fans is limited to a simplified check as prescribed by the maintenance plan and maintenance report.

Bearing replacement times do not apply and are instead based on the condition.

The use of the relevant monitoring system does not release the user from carrying out the maintenance work listed in the TROX X-FANS maintenance report. The system owner bears full responsibility for any maintenance work that deviates from this or that is not performed in full.

9.3.1.1 TROX TLT VD fan diagnostic system

The TROX X-FANS fan status monitoring system monitors the state of the fan by measuring physical characteristics.

Following the prescribed functional and test runs, the general functional state of the fan is displayed on the fan data recorder (VDR) or a remote display unit using a traffic light function (green = OK, yellow = warning, red = alarm). If yellow or red is displayed, the fan must be maintained and the fault may need to be eliminated.

It is recommended to analyse the measurement data saved in the fan data recorder, as this may simplify the troubleshooting process. During commissioning, the first functional check is completed as a reference run.

9.3.1.2 Bearing status monitoring systems

Prüftechnik or SPM monitoring systems must be used.

The measured characteristics (including the total vibration velocity in the 10 – 1000 Hz range) must be evaluated by the system owner or the specialist company it commissions, and this work must be carried out in accordance with ISO 14694 (2003) (see 'Tables' on page 52 in the appendix).

9.4 Maintenance

See: 'Maintenance report' on page 49

9.4.1 Lubrication

See: 'Heavyweight bearing - TROX X-FANS - Variant "8"' on page 60 and 'Heavyweight bearing - TROX X-FANS - Variant "9"' on page 62

9.4.2 Replacing the motor bearings

Work on the electric motor must only be carried out by a qualified electrician or a suitable motor winding company.

9.5 Repair

9.5.1 Replacing the impeller and electric motor

For more information, see 'Installation manuals' on page 55

9.6 Measures following maintenance work

Carry out the following steps after completing the maintenance work and before activation:

1. ▶ Check that all of the screw connections loosened previously are secure.
2. ▶ Check whether all of the protective devices and covers removed previously have been reinstalled properly.
3. ▶ Ensure that all of the tools, materials and other equipment used have been removed from the work area.
4. ▶ Clean the work area and remove any spilled substances such as liquids, processing materials or similar products.
5. ▶ Ensure that all of the system safeguards work properly.



IMPORTANT!

The valid technical guidelines and building regulations on the commissioning / maintenance and installation of ventilation systems must be observed. Ensure that nobody is in the hazardous area.

10 Decommissioning

Once the period of use of the device has expired, the device must be removed and disposed of in an environmentally friendly manner.

10.1 Safety

Personnel

- Disassembly must only be carried out by specially trained specialist personnel.
- Work on the electrical system must only be carried out by qualified electricians.

Electrical system

DANGER!

Danger of death due to electric current!

Danger of electric shock! Do not touch any live components! Live electrical components may execute uncontrolled movements and cause serious injury.

Therefore:

- Before starting disassembly work, switch off the power supply and disconnect it permanently.

Explosion protection

EXPLOSION HAZARD!

Ignition sources, such as sparks, naked flames and hot surfaces, can lead to explosions in potentially explosive atmospheres. The following therefore applies to all disassembly work carried out on the unit in the Ex area:

- *Get written permission before you start the work.*
- *Only perform disassembly work if there is no potentially explosive atmosphere.*
- *Use only tools that have been approved for use in areas with potentially explosive atmospheres.*

Failure to comply with these notes leads to loss of explosion protection and may result in serious injury and death.

WARNING!

Risk of injury due to incorrect disassembly!

Stored residual energy, angular components, sharp edges and corners on and in the unit or on the required tools can cause injuries. Therefore:

Therefore:

- Before starting the work, ensure that there is enough space.
- Handle open, sharp-edged components with care.
- Disassemble components properly. Be aware that some components are very heavy. Use hoisting devices if necessary.
- Secure components so that they do not fall down or topple over.
- Consult the manufacturer if anything is unclear.

10.2 Disassembly

Before starting disassembly:

- Switch off the unit and secure it against being switched back on again.
- Physically disconnect the unit from the power supply and discharge any residual energy.
- Remove any operating materials, auxiliary materials and residual processing materials, and dispose of them in an environmentally-friendly manner.

Then professionally clean sub-assemblies and components and dismantle them in accordance with local occupational safety and environmental protection regulations.

10.3 Disposal

If no return or disposal agreement is in place, any disassembled components should be recycled:

- Scrap the metals.
- Take plastic parts to be recycled.
- Dispose of other components in a suitable manner, i.e. depending on their material properties.

ENVIRONMENT!

Environmental damage due to improper disposal!

Electronic waste, electronic components, lubricating and other auxiliary materials must be treated as hazardous waste and must only be disposed of by approved specialist companies!

The local municipal authority or specialist disposal companies provide information about environmentally-friendly disposal.

11 Lists of replacement parts

! NOTICE!

Incorrect or faulty replacement parts and components from other manufacturers can cause severe damage. Any warranty and service claims shall lapse without prior notification if non-approved replacement parts are used.

Therefore:

Only use original replacement parts provided by the manufacturer

Provide the following information when ordering replacement parts from the manufacturer:

- Type ¹⁾
- Manufacturing number: ¹⁾

¹⁾ See rating plate



Replacement parts

Replacement and wear parts that are not available at short notice should be in stock. Production downtime is usually more expensive than the cost of the part.

Please note that replacement parts not supplied by us are not checked and released by us. Any liability of the manufacturer is excluded for damages resulting from the use of non-original parts and accessories.

12 Index

A			
Accident.....	14	Installation manuals.....	40
Actuator.....	22	Belt drive.....	58
Additional equipment for axial fans.....	22	REH – disassembly of the impeller.....	56
Assembly		Removal/assembly of the complete rotor set - type RZH.....	57
Fan.....	28	Variant "8" - heavyweight bearing.....	60
Flexible connector.....	30	Variant "9" - lightweight bearing.....	62
Smoke extract.....	29	Installation outdoors.....	18
Spacing plates.....	30	Instruction.....	8, 35, 36, 37, 38
B		Isolator.....	13, 22
Belt drive.....	22	L	
C		Liability for defects.....	6
Casing.....	21	Limitation of liability.....	6
Checking delivered goods.....	24	List of faults.....	35
Commissioning.....	30	Lists of replacement parts.....	6
Commissioning report.....	10	Lubrication.....	40
Connection values.....	17	M	
Copyright.....	6	Maintenance.....	6, 39
Correct use.....	9	Maintenance report.....	10
Customer service.....	6	Motor.....	22
D		Moving components.....	12
Decommissioning.....	42	N	
Description of the sub-assembly.....	21	Noise.....	12
Design versions.....	16	Noise emission values.....	17
Disassembly.....	42	O	
Disposal.....	42	Operating conditions.....	18
E		Operating modes.....	18
Electric current.....	12	Operation.....	32
Emergency stop.....	32	P	
Explanation.....	5	Packaging.....	24
Explosion protection.....	9, 31	Parts and function.....	13
F		Personal protective equipment.....	11, 38
Factory settings.....	25	Personnel.....	38
Falling materials.....	13	Disassembly.....	42
Fan.....	12	Faults.....	33
Faults.....	33	Initial commissioning.....	27
Fire.....	14	Installation.....	27
First aid.....	14	Personnel requirements.....	8
Fixing.....	22	Protective equipment	
G		Installation.....	27
General.....	5	R	
H		Rating plate.....	17
Hazardous area.....	14	Repair.....	40
I		Replacement parts.....	6
Impeller.....	21	Replacing the impeller and electric motor.....	40
Initial commissioning.....	31	Replacing the motor bearings.....	40
Installation.....	28		
Installation and commissioning.....	6		

S			
S1 continuous operation.....	18	Terminal box.....	22
S9 speed-controlled operation.....	18	Transport.....	24, 25
Safeguards.....	13	Crane.....	25
Safety.....	8	Forklift.....	25
Secured isolator.....	14	Lashing lugs.....	25
Series.....	16	Transport, packaging and storage.....	24
Skilled qualified electrician.....	8, 35, 36, 38	Type code.....	16
Smoke extract.....	19, 28	Types	
Specialist personnel.....	8	BVRA.....	17
Specific hazards.....	12	BVREH.....	17
Storage.....	24, 26	REH-B-M.....	16
Suspended loads.....	13	REH-M3.....	16
Symbols on the packaging.....	25	REH-R.....	17
System owner's responsibility.....	8	RZH.....	17
T		U	
Tables.....	19	Unauthorised persons.....	9
Fan rating groups.....	53	V	
Impeller gap for centrifugal fans.....	53	VD fan diagnostic system.....	22, 40
Permissible vibration velocities.....	52	Vibrations.....	12
Screw tightening torques.....	52	Volume flow rate measuring unit VME.....	22
Tightening torques of the taper-lock clamping bushes.....	54		
Technical data.....	16		

Appendix

A Commissioning report

Building:		Date: __ . __ . 20__
Fan type:		
Company number:		
Approval number CE-EN 12101-3 (BV only)		

Rating plate data		
Name	Item	Unit
Volume flow rate		m ³ /h
Speed		rpm
Density		kg/m ³
Motor type		
Motor no.		
Nominal voltage		V
Nominal voltage		A
Mains frequency		Hz
Nominal power		kW
Motor speed		rpm

Operating conditions		
Name	Comment / specification	
Operating mode	Operation on demand	<input type="checkbox"/>
	Combined ventilation and smoke extract operation	<input type="checkbox"/>
Flow medium	Clean Air	<input type="checkbox"/>
	Dust-laden air	<input type="checkbox"/>
Other medium		<input type="checkbox"/>
Installation	Vertical installation location	<input type="checkbox"/>
	Horizontal installation location	<input type="checkbox"/>
	Fan assembled on vibration isolators	<input type="checkbox"/>
	Fan assembled with flexible connectors	<input type="checkbox"/>

Checklist		
Before commissioning, the system must be checked using the following checklist. If all the points on the checklist have been met, the fan is ready for commissioning using the control installed on the customer's premises.		
No.	Check	
1	Fan is free of foreign matter (tools, dirt, etc.).	<input type="checkbox"/>
2	Impeller rotates freely.	<input type="checkbox"/>
3	Impeller gap corresponds to information provided in Chapters 12.3.4 and 12.3.5	<input type="checkbox"/>
4	Screw connections are secure (see screw tightening torques in Chapter 12.3.1).	<input type="checkbox"/>

Checklist

Before commissioning, the system must be checked using the following checklist. If all the points on the checklist have been met, the fan is ready for commissioning using the control installed on the customer's premises.

No.	Check	
5	Cover grilles are secure (during free inlet or free outlet) (see screw tightening torques in Chapter 12.3.1).	<input type="checkbox"/>
6	Duct system is assembled in full.	<input type="checkbox"/>
7	Pressure side and intake side connecting parts are assembled in full.	<input type="checkbox"/>
8	Inspection hatch is accessible and closed.	<input type="checkbox"/>
9	Electronic protective devices (emergency stop switch, motor overload switch, earth resistance) are installed correctly.	<input type="checkbox"/>
10	Electric motor is connected according to the terminal diagram.	<input type="checkbox"/>
11	Check the electric motor's direction of rotation: <ul style="list-style-type: none"> ▪ Briefly supply the electric motor (< 1 s) with supply voltage ▪ Compare the direction of rotation with the arrow on the fan casing. ▪ Reconnect the supply lines if it does not match. 	<input type="checkbox"/>
12	Carry out and log the checks and functional check according to the maintenance report (12.2.3).	<input type="checkbox"/>
13	In the case of speed-controlled fans, check vibrations throughout the entire operating speed range.	<input type="checkbox"/>
	IMPORTANT! In the version with VD, the first functional check is automatically saved as the reference run. This is used as a comparison for all subsequent functional checks under the same operating conditions.	

Notes

Commissioning carried out by:	Date	Signature
Executor		
System owner		

B Maintenance report

Building:		Date: __ . __ . 20__
Fan type:		
Company number:		
Approval number CE-EN 12101-3 (BV only)		

Measurements to be performed (according to VDI 2044, ISO 5802)

Variable		Unit	Value measured by UBA	Measuring device
Supply voltage		V		
Operating current ¹	L1	A		
	L2	A		
	L3	A		
Volume flow rate		m ³ /h		
Vibrations, axial		mm/s		
Vibrations, radial		mm/s		
Speed		rpm		
Checklist ↪ <i>Table on page 50</i> filled out				

¹ If the measured value of the current is recorded using the current probe on the fan terminal box and star/delta circuit, the measured value must be multiplied by $\sqrt{3}$ and logged. If the nominal current is exceeded, the cause must be determined and eliminated according to .

Notes

Maintenance carried out by:	Date	Signature
Executor		
System owner		

Maintenance report checklist						
Maintenance work to be carried out in the relevant category	Ventilation	ATEX	Smoke exhaust fan			
			As standard	with VD	with VD +VME	with moni- toring system
To be carried out every six months by instructed personnel						
Fan is free of foreign matter (tools, dirt, etc.).			<input type="checkbox"/>	<input type="checkbox"/>	<input type="checkbox"/>	<input type="checkbox"/>
To be performed annually by instructed personnel						
Visual check of the general external condition of the device, contamination, damage and corrosion, and clean if necessary	<input type="checkbox"/>	<input type="checkbox"/>	<input type="checkbox"/>	<input type="checkbox"/>	<input type="checkbox"/>	<input type="checkbox"/>
Check flexible connector(s) for damage and ensure stress-free installation	<input type="checkbox"/>	<input type="checkbox"/>	<input type="checkbox"/>	<input type="checkbox"/>	<input type="checkbox"/>	<input type="checkbox"/>
Check the cooling air supply for a free cross section (VD monitors the motor temperature) - if present	<input type="checkbox"/>	<input type="checkbox"/>	<input type="checkbox"/>			<input type="checkbox"/>
Check the anti-vibration elements for free movement and damage	<input type="checkbox"/>	<input type="checkbox"/>	<input type="checkbox"/>			
Check the electrical fan terminal box and cables for damage and correct installation	<input type="checkbox"/>	<input type="checkbox"/>	<input type="checkbox"/>	<input type="checkbox"/>	<input type="checkbox"/>	<input type="checkbox"/>
Check the impeller for damage and free movement	<input type="checkbox"/>	<input type="checkbox"/>	<input type="checkbox"/>			
Perform a functional check: 20 minutes ²	<input type="checkbox"/>	<input type="checkbox"/>	<input type="checkbox"/>	<input type="checkbox"/>	<input type="checkbox"/>	<input type="checkbox"/>
Check the direction of rotation	<input type="checkbox"/>	<input type="checkbox"/>	<input type="checkbox"/>	<input type="checkbox"/>	<input type="checkbox"/>	<input type="checkbox"/>
Check the electric motor's current consumption	<input type="checkbox"/>	<input type="checkbox"/>	<input type="checkbox"/>			<input type="checkbox"/>
Measurement and evaluation of the bearing condition						<input type="checkbox"/>
Read off the VD display (check "traffic lights" and display values) or read out data				<input type="checkbox"/>	<input type="checkbox"/>	
To be performed annually by specialist personnel						
Check the vibration state ³	<input type="checkbox"/>	<input type="checkbox"/>	<input type="checkbox"/>			

² Note: In the construction with VD, the first functional check is automatically saved as the reference run. This is used as a comparison for all subsequent functional checks under the same operating conditions

³ The values specified in the operating manual must be observed. The values must be determined according to ISO 14694.

⁴ The service life of the bearings is generally 20,000 h, but the actual service life can deviate considerably from this value depending on the bearing load. The operating instructions provided by the motor manufacturer are available for download from the manufacturer's website.

⁵ Recommendation: An annual bearing check should be performed.

Maintenance report checklist						
Maintenance work to be carried out in the relevant category	Ventilation	ATEX	Smoke exhaust fan			
			As standard	with VD	with VD +VME	with moni- toring system
To be performed every 3 years by specialist personnel						
Measure the volume flow rate			<input type="checkbox"/>	<input type="checkbox"/>		<input type="checkbox"/>
To be performed every three years by the manufacturer or an authorised specialist company from the fifth year following manufacture						
Check the bearings ⁴			<input type="checkbox"/>			<input type="checkbox"/>
To be performed by the manufacturer or authorised specialist company according to the condition						
Replace the motor bearings ⁵	<input type="checkbox"/>	<input type="checkbox"/>	<input type="checkbox"/>	<input type="checkbox"/>	<input type="checkbox"/>	<input type="checkbox"/>

² Note: In the construction with VD, the first functional check is automatically saved as the reference run. This is used as a comparison for all subsequent functional checks under the same operating conditions

³ The values specified in the operating manual must be observed. The values must be determined according to ISO 14694.

⁴ The service life of the bearings is generally 20,000 h, but the actual service life can deviate considerably from this value depending on the bearing load. The operating instructions provided by the motor manufacturer are available for download from the manufacturer's website.

⁵ Recommendation: An annual bearing check should be performed.

C Tables

Table of screw tightening torques

	Maximum tightening MA in Nm								
	Strength category								
	8.8			10.9			12.9		
	Sliding friction coefficient μ^8								
	0.10	0.15	0.20	0.10	0.15	0.20	0.10	0.15	0.20
M8	20	25	30	30	37	44	35	43	52
M10	40	50	60	59	73	87	69	51	100
M12	69	87	105	100	125	151	120	148	177
M16	170	220	260	250	315	380	290	370	445
M20	340	430	520	490	615	740	570	700	840
M24	590	740	890	840	1050	1250	980	1250	1500

8

- $\mu = 0.10$ very good surface, lubricated
- $\mu = 0.15$ good surface, lubricated or dry
- $\mu = 0.20$ surface is black or phosphate-treated, dry

Table of permissible vibration velocities

According to ISO 14694 (2003), Chapter 8.4

State	Category	Max. vibration velocity, securely assembled, [mm/s]	Max. vibration velocity, flexibly assembled, [mm/s]
Commissioning	BV-2	5.6	9.0
	BV-3	4.5	6.3
	BV-4	2.8	4.5
Normal operation	BV-2	5.6 – 9.0	9.0 – 14.0
	BV-3	4.5 – 7.1	6.3 – 11.8
	BV-4	2.8 – 4.5	4.5 – 7.1
Alarm	BV-2	9.0 – 12.5	14.0 – 17.5
	BV-3	7.1 – 9.0	11.8 – 12.5
	BV-4	4.5 – 7.1	7.1 – 11.2
Shutdown	BV-2	≥ 12.5	≥ 17.5
	BV-3	≥ 9.0	≥ 12.5
	BV-4	≥ 7.1	≥ 11.2

Table of the fan rating groups

According to ISO 14694 (2003), Chapter 8.4

Application	Max. drive capacity [kW]	Fan rating group
Building ventilation	≤ 3.7	BV-2
	> 3.7	BV-3
Hazardous gases	≤ 37	BV-3
	> 37	BV-4

Impeller gap table for centrifugal fans

Size	Impeller gap (+ tolerance) in mm	Immersion depth (+ tolerance) in mm
315	1.5 (+3.0)	2.0 (+5.0)
355	1.5 (+3.0)	2.0 (+5.0)
400	2.0 (+3.0)	2.0 (+6.0)
450	2.0 (+3.0)	2.0 (+6.0)
500	3.0 (+3.0)	3.0 (+7.0)
560	3.0 (+3.0)	3.0 (+7.0)
630	4.0 (+3.0)	4.0 (+8.0)
710	4.0 (+3.0)	4.0 (+8.0)
800	4.0 (+3.0)	4.0 (+8.0)
900	4.0 (+3.0)	4.0 (+8.0)
1000	5.0 (+3.0)	5.0 (+8.0)
1120	5.0 (+4.0)	5.0 (+8.0)
1250	6.0 (+4.0)	5.0 (+10.0)
1400	6.0 (+6.0)	8.0 (+10.0)
1600	7.0 (+6.0)	8.0 (+10.0)

Installation of the taper-lock clamping bushes - tightening torques

Bush type	Screw tightening torques in Nm
1008	5.7
1108	5.7
1210	20
1215	20
1310	20
1610	20
1615	20
2012	31
2517	49
3020	92
3030	92
3035	115
4040	172
4545	195
5050	275

D Installation manuals

D.1	Type REH – assembly/disassembly of the impeller.....	56
D.2	Type RZH - removal/assembly of the complete rotor set.....	57
D.3	Belt drive.....	58
D.4	Bearing.....	59
D.4.1	Bearing variant "8" (heavyweight bearing).....	60
D.4.2	Bearing variant "9" (lightweight bearing).....	62

D.1 Type REH – assembly/disassembly of the impeller

Removal

! NOTICE!

Appropriate measures (e.g., using supports) must be taken to prevent the impeller from falling.

! WARNING!

The fan must be secured against being switched on and off.

1. ▶ Loosen and remove the screws of the bellmouth inlet. Remove the bellmouth inlet towards the intake side.
2. ▶ Loosen all taper-lock bush screws. Depending on the bush size, unscrew one or two screws completely, oil the screw(s) and screw the screw(s) into the forcing hole.
3. ▶ Tighten the screw or screws evenly until the bush detaches from the hub and the washer can be moved freely on the crankshaft.
4. ▶ Remove the washer with bush from the crankshaft.

Installation

1. ▶ Clean all bare surfaces, such as the drilled hole and cone of the tapered clamping bush, as well as the conical drilled hole of the washer, and grease them. Insert the tapered clamping bush into the hub and cover all drilled holes (half threaded drilled holes must face semi-smooth drilled holes).
2. ▶ Lightly oil and screw in threaded pins (size 1008 - 3030) or cheese-head screws (size 3535 - 5050). Do not tighten the screws yet.
3. ▶ Clean and degrease the crankshaft, push the washer with tapered clamping bush to the desired position on the crankshaft.
4. ▶ When using a keyway and the drilled hole groove, rear clearance must be present.
5. ▶ Using a DIN 911 screwdriver, tighten threaded pins or cheese-head screws evenly with the tightening torques specified in table ↪ 'Installation of the taper-lock clamping bushes - tightening torques' on page 54.
6. ▶ To prevent the penetration of foreign matter, fill empty drilled holes with grease.
7. ▶ Align the bellmouth inlet and check the airway width. Please refer to the assembly drawing for the dimension of airway width "S".
8. ▶ Tighten the fixing screws of the bellmouth inlet firmly!
9. ▶ After a short operating time (1/2 to 1 hour), check the tightening torque of the screws and correct it if necessary.

! NOTICE!

After installation, the smooth running of the impeller must be checked. The values of ISO 10816-3 with the following assessment limits must be observed.

Assessment limit	good	Usable
Corresponds to the effective velocity V_{eff}	max. 2.8 mm	max. 7.0 mm

D.2 Type RZH - removal/assembly of the complete rotor set

WARNING!

Attention! The impeller and crankshaft must not be separated.

Removal of nominal size 400-1000

1. ▶ De-energize the fan
2. ▶ Remove the V-belt drive and belt protection box.
3. ▶ Secure the rotor set against falling
4. ▶ Disassembly of the bearing (↪ *'Heavyweight bearing - TROX X-FANS - Variant "8"'* on page 60 and ↪ *'Dis-assembly of lightweight bearing TROX X-FANS variant "9"'* on page 62)
5. ▶ Disassembly of inlet cover grille on the actuator side
6. ▶ Disassembly of the bearing block (support frame) on the actuator side
7. ▶ Disassembly of bellmouth inlet on the actuator side
8. ▶ Pull out the complete rotor set on the actuator side with suitable lifting tools

Installation of nominal size 400-1000

1. ▶ Step 1 - 8 in reverse order; proceed as under ↪ on page 57
2. ▶ Align the bellmouth inlet (airway width "S" according to TROX X-FANS drawing)

Removal of nominal size 1120-1600

1. ▶ De-energize the fan
2. ▶ Remove the V-belt drive and belt protection box.
3. ▶ Secure the rotor set against falling
4. ▶ Disassembly of the bearing (↪ *'Heavyweight bearing - TROX X-FANS - Variant "8"'* on page 60 and ↪ *'Dis-assembly of lightweight bearing TROX X-FANS variant "9"'* on page 62)
5. ▶ Disassembly of both inlet cover grilles
6. ▶ Disassembly of bellmouth inlet on the actuator side
7. ▶ Disassembly of top of casing using suitable lifting gear
8. ▶ Lift the complete rotor set up and out using suitable lifting gear

Installation of nominal size 1120-1600

1. ▶ Step 1 - 8 in reverse order; proceed as under ↪ on page 57
2. ▶ Align the bellmouth inlet (airway width "S" according to TROX X-FANS drawing)

D.3 Belt drive

The fan shaft is driven by a narrow V-belt drive. The belt pulleys must be precisely aligned, and the belt tension must comply with requirements. The grooves of the V-belts must be free from rust, grease and dirt and must not be damaged. Contamination by oils, greases or chemicals must be avoided.



In the case of multi-groove V-belt pulleys, only V-belt sets of the same length are to be used when replacing worn-out V-belts. Unusual individual V-belts can only be replaced by complete V-belt sets. After approx. 1 to 2 hours of full load operation with a new V-belt set, the pre-tension of the V-belts must be checked, and, if necessary, the belts must be retensioned.

V-belt assembly

WARNING!

Turn off the mains isolator before starting maintenance. Remove the protective devices only when the fan is at a standstill!

1. ▶ Unclamp the V-belt drive by reducing the axis distance with the V-belt clamping device.
2. ▶ Insert the V-belts into the grooves of the V-belt pulleys by hand and without the use of force.
3. ▶ Clamp the V-belt drive by increasing the axis distance with the V-belt clamping device. The required V-belt tension described below must be observed.

V-belt tension

The correct V-belt pre-tension is of enormous importance for perfect power transmission and achievement of the usual V-belt life. Pre-tension that is too low or too high often leads to a premature failure of the V-belts and bearing defects. We recommend that you calculate the required static force in the span individually for each actuator.

D.4 Bearing



WARNING!

Attention! Observe the "Occupational safety" section. ↪ 2 'Safety' on page 8

D.4.1 Bearing variant "8" (heavyweight bearing)

Heavyweight bearing - TROX X-FANS - Variant "8"

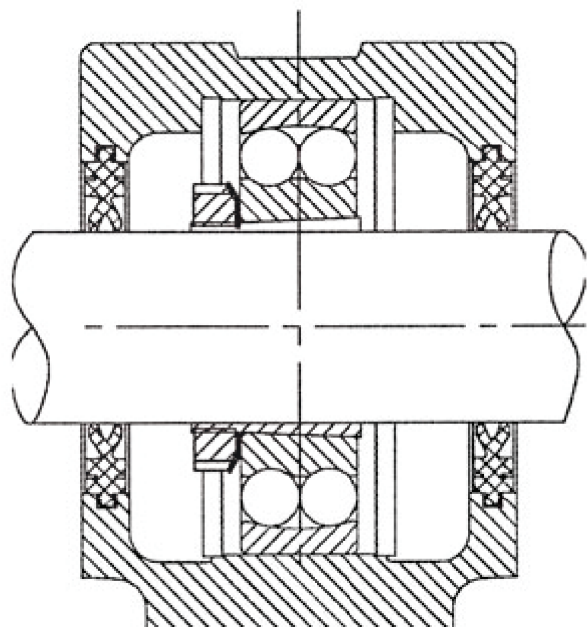

Fig. 27: Plummer block casing with self-aligning ball bearing, floating bearing



The crankshaft of the fan is guided in two single plummer block casings, which are attached to the crankshaft by means of clamping sleeves. The casing body of the plummer block casing is divided horizontally and is provided with lithium-saponified quality grease at the production facility. The sealing is implemented using a two-lip seal.

This bearing has no relubrication device. Maintenance of these bearings is limited to occasional grease changes according to the sticker on the bearing casing. For the grease change, lithium-sifted grease must be used. The specified grease amounts are approximate values. For this purpose, the casing is opened, the bearing is dismantled and the grease is completely removed. Then apply grease to the bearing. In individual situations, proceed as follows:

Disassembly of the plummer block casings with self-aligning ball bearing - heavyweight bearing TROX X-FANS variant "8"

1. ▶ Loosen the fixing screws of the top of the casing
2. ▶ Remove the top of the casing upwards.
3. ▶ Bend up the locking plate on the clamping sleeve nut and turn it back by a few threads.
4. ▶ Remove the casing foot screws
5. ▶ Support the impeller
6. ▶ Loosen the clamping sleeve by hitting it lightly and axially with a striking tool. In the process, turn the crankshaft bit by bit.

! NOTICE!

Do not hit the bearing rings with the striking tool!

7. ▶ Remove the bottom of the casing with the roller bearing and clamping sleeve.

8. ▶ Wash out the bearing and check for damage to the treads, rolling elements and cage.
9. ▶ Grease the bearing with the amount of grease specified on the sticker on the bearing casing.

Assembly of the plummer block casings with self-aligning ball bearing - heavyweight bearing TROX X-FANS variant "8"

1. ▶ Check the clamping surface of the bearings.
2. ▶ Push the bottom of the casing onto the crankshaft with the inserted complete roller bearing and both two-lip seals. In the drive-side fixed bearing, attach the fixed ring to attach the roller bearing between the seal and the bearing. The loose bearing should sit in the middle of the casing.
3. ▶ Fix the bottom of the casing into place.
4. ▶ Tighten the clamping sleeve nut until the roller bearing sits on the clamping sleeve in a force-locked manner. In the circumferential direction, the ring must still be able to be rotated freely.
5. ▶ Bend down a lug on the locking plate to secure the clamping sleeve nut.
6. ▶ Align the bottom of the casing and tighten the fixing screws.
7. ▶ Distribute the remaining grease evenly in the casing after the storage grease. The casing must only be filled up to a maximum of 1/3 of the volume.
8. ▶ Place the top of the casing and tighten the connecting screws.

! NOTICE!

The impeller must be easy to turn by hand!

Assembly of the self-aligning ball bearing - heavyweight bearing TROX X-FANS variant "8"

Bearings with a conical drilled hole are always mounted with a fixed fit on the crankshaft with a clamping sleeve. As a measure of the strength of the fit, the tightening angle "a" or axial displacement "s" can be used for self-aligning ball bearings.

If the tightening angle "a" is used for assembly, proceed as follows:

1. ▶ Before assembly, lubricate the side of the clamping sleeve nut facing the bearing with a molybdenum disulfide paste and coat the sheath surfaces of the clamping sleeve with thin oil.
2. ▶ Slide the bearing onto the sleeve, and then screw on the nut.
3. ▶ Press the bearing onto the sleeve by tightening the nut.
4. ▶ If the bearing is properly mounted, the outer ring must be easily rotated in the circumferential direction.

! NOTICE!

In case of longer downtimes (approx. 1 year), the grease must be renewed before commissioning.

D.4.2 Bearing variant "9" (lightweight bearing)

Heavyweight bearing - TROX X-FANS - Variant "9"

Roller bearing (RASE) lubricated for approx. 20,000 operating hours. Can be relubricated during operation upon desire.

Disassembly of lightweight bearing TROX X-FANS variant "9"

in reverse order; proceed as under ↶ *'Assembly of lightweight bearing TROX X-FANS variant "9"' on page 62*

! NOTICE!

In case of longer downtimes (approx. 1 year), the grease must be renewed before commissioning.

Assembly of lightweight bearing TROX X-FANS variant "9"

1. ▶ Push the bearing unit onto the crankshaft
2. ▶ Screw the casing into place
3. ▶ Tighten the eccentric ring by hand, preferably in the direction of rotation of the crankshaft
4. ▶ Tighten with mandrel and hammer
5. ▶ ② Threaded pin

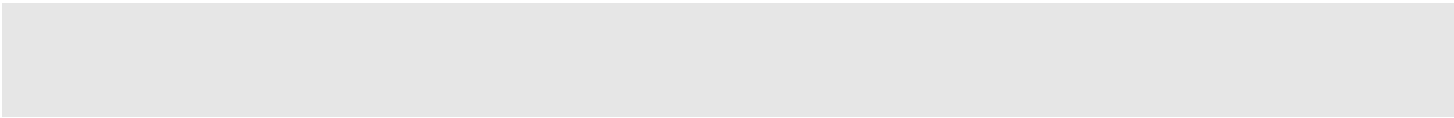

TROX[®] TECHNİK

The art of handling air

TROX X-FANS GmbH

Heinz Trox Str. 1
36251 Bad Hersfeld, Germany
+49 6621/950-0

+49 6621/950-100
info-xfans@trox.de
www.trox-xfans.de

© 2018